

field Guide **TO TANK CARS**

Fourth Edition



**ASSOCIATION OF
AMERICAN RAILROADS**



Initial Notification

When you are the first on scene of a rail transportation accident, your first step is to avoid endangering yourself and call for help. Immediately notify the local emergency response agency and the rail transportation carrier. Contact the operating railroad directly via its Emergency Response Number for response and technical assistance.

Emergency Response Numbers for Major Rail Carriers

BNSF Railway	800-832-5452
Canadian National Railway	800-465-9239
Canadian Pacific Railway	800-716-9132
Conrail	800-799-0994
CSX Transportation	800-232-0144
Kansas City Southern Railway	877-527-9464
Norfolk Southern Railway	800-453-2530
Union Pacific Railroad	888-877-7267
Railway Association of Canada	
<i>RAC personnel are available for emergency response and technical assistance at railroad incidents involving dangerous goods in Canada.</i>	1-647-206-2896

Field Guide to Tank Cars

Compiled by Allen D. Maty, Bureau of Explosives (Ret.) and Charles J. Wright, Union Pacific RR (Ret.)

Issued by:

Association of American Railroads/Bureau of Explosives
425 Third Street, SW Suite 1000
Washington, DC 20024

Andy Elkins
AElkins@aar.org
202-639-2100
www.aar.org

Printed in the United States of America
Copyright © 2022 by the Association of American Railroads, all rights reserved,
Fourth Edition (2022)
Later Editions will supersede this document.

Do not alter.
Do not copy or distribute without express authorization from AAR.
Not for sale or re-publication.

Acknowledgements

In 1992, the Association of American Railroads' (AAR) Bureau of Explosives (BOE) published a document entitled "*Field Guide to Tank Car Identification*". In 2010, the BOE published the "*Field Guide to Tank Cars*"; a Second Edition was published in 2012, with a Third Edition in 2017.

The AAR and BOE have gratefully acknowledged the assistance of the following companies for granting permission to use their tank car drawings: GATX Corporation, Midland Manufacturing Company, UTLX Manufacturing, Trinity Industries, Inc., Chart Industries, The Chlorine Institute, Railway Association of Canada, Veolia North America, Salco Products, Transquip USA, Kelso Technologies, Inc., Canadian National Railway, Kansas City Southern Railway, Norfolk Southern Railway Company, and the Railway Association of Canada (RAC).

The following individuals assisted in the preparation of the above documents:

- Andy Ash
- Patrick Brady
- Sam Chapman
- Anthony Ippolito
- Robyn Kinsley
- Jim Kozey
- Allen Maty
- Steve McNealy
- N. Scott Murray
- Tim O'Brien
- William Oertly
- Allen Richter
- Glen Rudner
- Lane Sekavec
- Patrick Student
- Paul Williams
- Charles Wright.

We wish to acknowledge the following individuals for their assistance in preparing this, the fourth Edition of the *Field Guide to Tank Cars*:

- Andy Ash (RAC)
- Christopher Baxter (Olin Corp.)
- Ken Dorsey (AAR)
- Andy Elkins (AAR)
- Dennis Foley (Neles Corp.)
- Anthony Ippolito (CN)
- Scott Karcher (CSX)
- Hira Khalid (AAR)
- Robyn Kinsley (Chlorine Institute)
- Michael Moore (UP)
- Clay Reid (BNSF)
- Brian Shanks (NS)
- Joe Taylor (CSX)
- Paul Williams (NS).

The AAR and BOE thank the following for providing additional graphics included in this edition:

- Alltranstek
- Barry Lindley
- Robert Fronczak (AAR)
- Railway Supply Institute (RSI)
- Rapik Saat (AAR)
- Union Tank Car Company
- Trinity Industries.

Dedication

Field Guide to Tank Cars is dedicated to the memory of:

Mr. Roy J. Holden
(1921–1989)

Engineer, Technical Services
Bureau of Explosives
Association of American Railroads

“Uncle Roy” was a pioneer in the development of tank car damage assessment techniques. His wit, wisdom, experience, and dedication to tank car safety are sorely missed.



Photo courtesy of Peter Conlon

Contents

Introduction	9
Section 1: Tank Car Classification & Specifications	11
Section 2: Tank Car Safety Systems	15
Pressure Relief Devices.....	16
Pressure Relief Device Settings	20
Section 3: Tank Car Stenciling and markings	22
Section 4: Nonpressure Tank Cars.....	26
Section 5: Pressure Tank Cars	48
Fittings for the Most Common Commodities Shipped in Pressure Tank Cars.....	50
Top Fittings Protection Requirements for Tank Cars Transporting Materials Poisonous (Toxic) by Inhalation (PIH/TIH Materials).....	55
Alternative Fittings Package and Tank Car Designs for PIH/TIH Materials.....	56
Alternative Fittings Package	56
Alternative Tank Car Design.....	56
Section 6: Cryogenic Liquid Tank Cars.....	60
Section 7: Guidelines for Initial Emergency Response.....	63
Initial Notifications	63
Initial Actions	64
Identifying Commodities Involved.....	65
Tank Car Damage Assessment.....	65
Safety Issues	66
Inspecting Damaged Tank Car Tanks.....	66
Flame Impingement Issues.....	67
Rail Carrier Resources.....	67
Section 8: Glossary of Railroad & Tank Car Terms.....	69
Annex A: AAR, U.S. DOT, & Transport Canada Safety Enhancements for Nonpressure Tank Cars	78
AAR-INITIATED SAFETY ENHANCEMENTS FOR NONPRESSURE TANK CARS.....	78
Top Fittings Protection for Tank Cars in Sulfuric Acid Service.....	78
Top Fittings Protection for Tank Cars Used to Transport Packing Group I & II Materials	78
Tank Cars Built for the Transportation of Class 3 (Flammable Liquids).....	78
U.S. DOT REGULATIONS FOR TANK CARS IN CLASS 3 (FLAMMABLE LIQUID) SERVICE	79
Tank Cars in “High-Hazard Flammable Train Service”	79
Excerpted from Title 49CFR:	79
TRANSPORT CANADA REGULATIONS FOR TANK CARS.....	83
Transport Canada Protective Direction No. 34.....	83
TC-117 Tank Cars for Flammable Liquids.....	83
Transport Canada Protective Direction No. 38.....	83

Table of Figures

Specification: DOT-111A100ALW1.....	11
Tank Car Designator Table	13
Rail Car Orientation Diagram	14
Tank Cars Registered by Class Number for Use in North America.....	14
Double-Shelf Couplers.....	15
Head Shield	15
Protective Housing.....	16
Bottom Discontinuity Protection (Skid)	16
Protective Skids.....	16
Reclosing Pressure Relief Valves for Nonpressure Tank Cars	17
Reclosing Pressure Relief Devices for Pressure Tank Cars	18
Nonreclosing Pressure Relief Devices (Safety Vents) (Aka “Rupture Disc Devices”).....	19
Vacuum Relief Valves.....	20
Identification Plate Format	22
Example Identification Plate in Place.....	23
Variable Identification Plate Format.....	23
Tank Car Qualification Stencil	24
Manway Style Marking.....	24
Typical Remote Monitoring Devices	25
Location of Key Stenciling	25
Clues for Recognizing Jacketed Tank Cars.....	28
DOT/TC-111A100W1 General Service Tank Car.....	30
DOT/TC-111A100W1 Tank Car with Protective Housing (Sodium Hydroxide)	31
DOT/TC-111A100W1 Tank Car without Protective Housing (Sodium Hydroxide).....	32
DOT/TC-111A100W2 Tank Car with Protective Housing (Sulfuric Acid).....	33
DOT/TC-111A100W2 Tank Car without Protective Housing (Sulfuric Acid)	34
DOT/TC-111A100W5 Tank Car with Protective Housing (Hydrochloric Acid)	35
Manway Arrangements with Different PRD Options for Hydrochloric Acid Tank Cars	36
DOT/TC-111A100W5 Tank Car without Protective Housing (Hydrochloric Acid).....	37
DOT/TC-111A100W6 Tank Car (Hydrogen Peroxide)	38
DOT/TC-111A100W7 Tank Car (Hydrogen Peroxide)	38
DOT/TC-111A100W1 (CPC-1232*) Tank Car (High-Hazard Flammable Liquids)	39
DOT/TC-117R100W Tank Car (High-Hazard Flammable Liquids).....	40
DOT/TC-117J100W Tank Car (High-Hazard Flammable Liquids)	41
Examples of Fitting Arrangements for Class DOT-117 Tank Cars	42
Comparison of Tank Cars for High-Hazard Flammable Liquids.....	42
Class DOT/TC-117 Bottom Outlet Operating Mechanism	43
DOT/TC-Class 111 Multi-compartment Tank Car.....	44
AAR-211A100W1 Tank Car (Food Products, Clay Slurry, Low-Hazard Hazardous Materials).....	44
Examples of Nonpressure Tank Car Service Equipment	45
Magnetic Gauging Device	49
DOT/TC-112J340W Tank Car (Liqefied Compressed Gases)	51
Fittings Arrangement - DOT/TC-112J340W Tank Cars.....	52
DOT/TC-112S500I Tank Car (Anhydrous Hydrogen Fluoride)	52
DOT/TC-105J500W Tank Car (Carbon Dioxide).....	54
DOT/TC-120J200W Tank Car (Flammable Liquids)	55
DOT/TC-112H500W Tank Car (PIH/TIH Materials).....	57
DOT/TC-105H600W Tank Car (PIH/TIH Materials).....	58
DOT/TC-105J (DOT-SP 15036/TC-SR 10521) Tank Car (Chlorine)	58
Cutaway View of Dual Valve Fittings for Chlorine Tank Cars.....	59

Typical Class DOT/TC-113 Tank Car (Cryogenic Liquids)	61
Typical Fittings Arrangement - Class DOT/TC-113 Tank Cars.....	62
DOT Phase-Out Dates for DOT-111 and DOT-111 CP-1232 Tank Cars in High-Hazard Flammable Train Service	80
DOT Phase-Out Dates for Non-DOT-117 Tank Cars in Class 3 (Flammable Liquids) Service (10/1/2015)	81
DOT Phase-Out Dates for Non-DOT-117 Tank Cars in Class 3 (Flammable Liquids)	82
Transport Canada Phase-Out Schedule for Tank Cars Transporting Class 3 (Flammable Liquids)	83
Transport Canada Accelerated Phase-Out Schedule for Tank Cars Transporting Class 3 (Flammable Liquids)	84

Introduction

The *Field Guide to Tank Cars* is intended to be used by emergency responders and others involved with railroad tank cars. It provides information on the types, safety systems, stenciling, and markings of tank cars utilized to transport regulated (hazardous materials/dangerous goods) and nonregulated commodities.

Given the varying characteristics of the different commodities being transported and the shipper's differing needs and uses, it is impossible to cover all the various types of tank cars and fittings used. The illustrations contained in this guide are intended to provide a general overview of tank car types, characteristics, and typical fittings. They show the most common types of single-unit tank cars (a tank car tank mounted on, or forming part of, a railcar structure) currently used to transport both regulated (hazardous materials/dangerous goods) and nonregulated commodities which do not require placards.

All railroad tank cars are built to specifications, standards, and requirements established, implemented, and published by the U.S. Department of Transportation (DOT), Transport Canada (TC), and/or Association of American Railroads (AAR). These specifications, standards, and requirements address tank car design, type, and thickness of material required to be used in construction, types of fittings, welding procedures, inspection, maintenance, repair, and quality assurance system requirements.

Note: Regulatory and railroad industry specifications, standards, and requirements are contained in: U.S. DOT Title 49 Code of Federal Regulations, Parts 173 (Subpart B), 174, 179, and 180 (Subpart F); Transport Canada Transportation of Dangerous Goods Regulations (Transport Canada TDG Regulations) and Containers for the Transport of Dangerous Goods by Rail (Standard TP 14877E); and Association of American Railroads Manual of Standards and Recommended Practices (MSRP) Section C-III, Specifications for Tank Cars, Specification M-1002.

Although there are many different single-unit tank cars, they can generally be divided into three separate categories:

1. **Nonpressure tank cars** (called “low pressure tank car” or “general service tank car” tank cars in the *2020 Emergency Response Guidebook*) typically transport a wide variety of liquid and solid regulated (hazardous materials/dangerous goods) as well as nonregulated commodities.

Note: The DOT and TC regulations use the term “nonpressure” for tank cars that transport liquids and solids; however, this does not necessarily mean that nonpressure tank cars are absent of internal tank pressure. Rather, nonpressure tank cars equipped with pressure relief devices having a discharge pressure from 75 to 165 psig may have a build-up of internal tank pressure. Therefore, caution should still be given when handling these tank cars.

2. **Pressure tank cars** are built with thicker tanks to withstand higher internal pressures, making them stronger than a nonpressure tank car. They typically transport liquefied compressed gases, poison/toxic inhalation hazard (PIH/TIH) materials, reactive materials, and/or some corrosive materials.
3. **Cryogenic liquid tank cars** are vacuum-insulated with an inner tank and carbon steel outer tank, not jacket. They transport refrigerated (extremely cold) liquefied gases having a boiling point colder than minus 130°F at atmospheric pressure, such as liquid hydrogen, oxygen, ethylene, nitrogen, methane (liquefied natural gas or LNG), and argon.

As information, UN portable tanks are not tank cars; therefore, they are not addressed in this document.

The *Field Guide to Tank Cars* is divided into eight sections and an annex:

- **Section 1: Tank Car Classification & Specifications**
Explains the various DOT, TC, and AAR tank car classes and specifications.
- **Section 2: Tank Car Safety Systems**
Describes the various pressure relief devices (PRDs) and other safety systems applied to protect the tank.
- **Section 3: Tank Car Stenciling and Markings**
Provides information on various stenciling/ markings required on tank cars by DOT, TC, and AAR.
- **Section 4: Nonpressure Tank Cars**
Describes the most common tank cars currently used to transport both liquid and solid regulated (hazardous materials/dangerous goods) and nonregulated commodities. This section also describes typical types of top and bottom valve and fittings arrangements with which these cars may be equipped.
- **Section 5: Pressure Tank Cars**
Describes the tank cars currently used to transport liquefied compressed gases under pressure, as well as some low-pressure, high-hazard materials, such as PIH/TIH materials, that may require the added protection of a stronger tank car.
- **Section 6: Cryogenic Liquid Tank Cars**
Describes the tank cars currently used to transport cryogenic liquids, such as argon.
- **Section 7: Guidelines for Initial Emergency Response**
Provides general guidance when approaching an incident involving tank cars in transportation. It also provides information on assessing damage to tank cars. This damage assessment information is presented to familiarize emergency responders with techniques used by trained and experienced professionals in analyzing and handling tank problems. It is not intended to replace on-scene judgment.
- **Section 8: Glossary of Railroad and Tank Car Terms**
Provides emergency responders and others involved with tank cars with some of the terminology associated with tank cars.
- **Annex A: AAR, U.S. DOT, & Transport Canada Safety Enhancements for Nonpressure Tank Cars**
Provides a detailed explanation of recent changes for nonpressure tank cars.

Section 1: Tank Car Classification & Specifications

DOT, TC, and the AAR have established specifications for the design, construction, testing/qualification, repair, and maintenance of tank cars. The tank car’s specification is required to be stenciled on both sides of the car. The following information defines the lettering. A sample specification appears on the next page.

Note: Transport Canada tank car specifications coincide with those of the Department of Transportation; therefore, “TC” may be substituted for “DOT” as the authorizing agency.

Current tank car specifications consist of the following information in order of presentation. Further explanation of this information is found on the following pages.

1. Authorizing agency
2. Class designation
3. Delimiter letter
4. Tank test pressure in pounds per square inch gauge (psig)
5. Material of construction when that material is other than carbon steel
6. In this position, “W” denotes fusion welding, and “I” indicates use for designated PIH/TIH material
7. Fittings, linings, materials

Specification: **DOT-111A100ALW1**

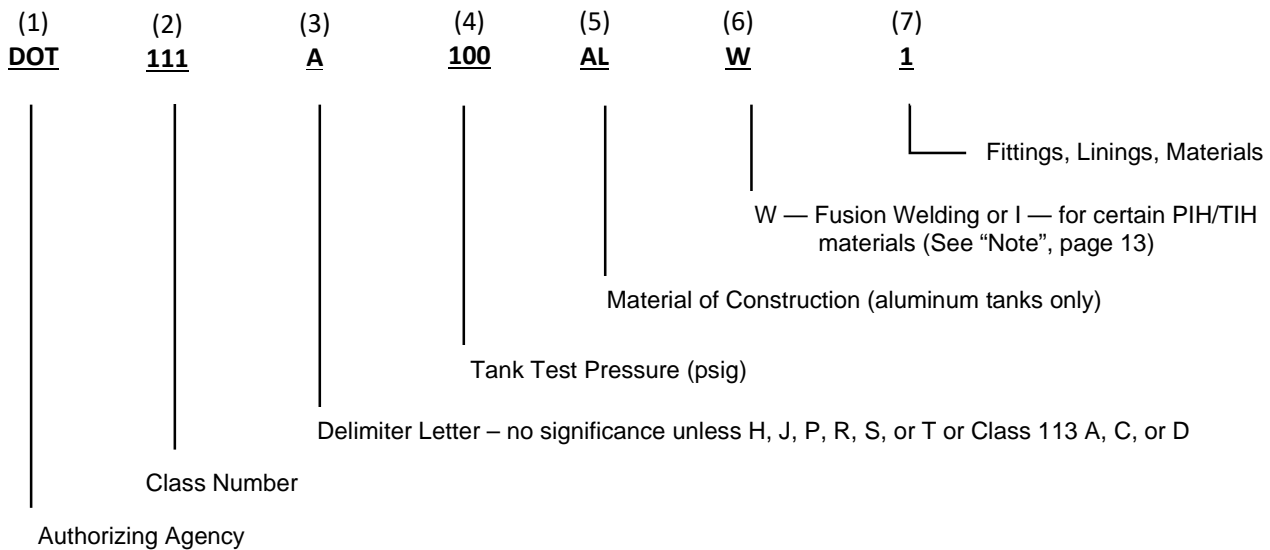

Components of the Specification Marking

1. **Authorizing Agency**
 - AAR: Association of American Railroads
 - DOT: U.S. Department of Transportation
 - TC: Transport Canada (replaced Canadian Transport Commission (CTC))

Note: In this document, the letters “TC” may be substituted for “DOT” when referring to a tank car’s class or specification; and, in some cases, the authorizing agency may not be shown preceding the class number (e.g., “Class DOT-111”, “Class TC-111” or “Class-111”).

2. **Class number:** The term “class” is a three-digit number used to identify general groupings of tank cars. A “class designation” usually includes several specifications and is made up of the authorizing agency followed by the three-digit class number, such as Class DOT-111, Class TC-111, or Class AAR-211.

- **Nonpressure Tank Car Classes**

- **DOT-111:** Insulated or uninsulated carbon steel, alloy (stainless) steel or aluminum tank.
- **DOT-115:** Insulated with a carbon or alloy (stainless) steel or aluminum inner container (tank) and a carbon steel outer shell (tank, not jacket). Also referred to as a tank-within-a-tank.
- **DOT-117:** Insulated or uninsulated carbon steel tank with jacketed thermal protection, full height head shields, and top fittings protection; a bottom outlet is optional. Additional information regarding Class-117 tank cars is contained in Section 4: Nonpressure Tank Cars.
- **AAR-206:** Insulated with an inner container (tank) and carbon steel outer shell (tank, not jacket), similar to Class-115 tank cars. Also referred to as a tank-within-a-tank.
- **AAR-211:** Insulated or uninsulated, similar to Class-111 tank cars.

- **Pressure Tank Car Classes**

- **DOT-105:** Insulated carbon or alloy (stainless) steel.
- **DOT-109:** Insulated or uninsulated, carbon steel or aluminum.
- **DOT-112:** Insulated or uninsulated, carbon or alloy steel.
- **DOT-114:** Insulated or uninsulated, carbon or alloy steel.
- **DOT-120:** Insulated carbon steel or aluminum.

- **Cryogenic Liquid* Car Classes**

- **DOT-113:** vacuum insulated with an alloy (stainless) steel or nickel alloy inner tank and carbon steel outer tank, not jacket.
- **AAR-204:** vacuum insulated with an inner alloy (stainless) steel tank and carbon steel outer tank, not jacket. These tank cars are similar in concept to Class-113 tank cars.

Note: **Cryogenic liquid is defined by U.S. 49CFR as: "A refrigerated liquefied gas having a boiling point colder than -130°F (-90°C) at atmospheric pressure". Transport Canada TP 14877E defines it as: "A refrigerated liquefied gas that is handled or transported at a temperature equal to or less than -100°C (-148°F)".*

3. Delimiter Letter: On pressure and nonpressure tank cars, the letter A separates the class from the tank test pressure and has no meaning. However, on pressure and some nonpressure tank cars, the delimiter letter is an indicator of tank head puncture resistance and/or thermal protection systems. On cryogenic liquid tank cars, the delimiter letter indicates the authorized lading loading temperature. On Class-117 tank cars, the delimiter letter corresponds to the tank cars as constructed (J), performance (P), or retrofitted (R) status.

- **Nonpressure or Pressure Tank Cars**

- **A** – No significance.
- **J** – Equipped with a thermal protection system that is covered by a jacket and tank head puncture-resistance system.
- **S** – Equipped with tank head puncture-resistance system.
- **T** – Equipped with a thermal protection system that is not covered by a jacket (the thermal protection material is sprayed directly onto the tank's surface) and tank head puncture-resistance system. Although authorized, not found currently in transportation.

- **Cryogenic Liquid Tank Cars**

- **A** – Authorized for minus 423°F loading.
- **C** – Authorized for minus 260°F loading.
- **D** – Authorized for minus 155°F loading.

- **Class-117 Tank Cars**

- **J** – Constructed to Class-117A specification.
- **P** – Existing nonpressure tank car that meets performance standards for a Class-117A.
- **R** – Existing nonpressure tank car that has been retrofitted to conform to the prescribed retrofit or Class-117A performance standards.

- 4. Tank Test Pressure:** The next set of digits is the tank test pressure in psig; typically, 20 to 40% of the tank’s burst pressure. For nonpressure tank cars, test pressures are specified as 60 or 100 psig; however, some manufacturers test 100-pound tanks to 165 psig, because they are equipped with 165 psig pressure relief devices (PRD), which equates to 33% of the tank’s 500 psig burst pressure. For pressure tank cars, test pressures range from 100 psig to 600 psig. For cryogenic liquid tank cars, tank test pressures range from 60 psig to 120 psig.
- 5. Material of Construction (other than steel):** The letters AL appearing after the tank test pressure indicate that the tank was constructed of aluminum. For other materials of construction, no letters or numerals are shown.
- 6. Fusion Welding:** The letter W following the tank test pressure, or the letters AL indicates that the tank was constructed using fusion welding. All tank cars are currently constructed using fusion welding.

Note: Tank cars built after March 16, 2009, and before December 28, 2020, used for transportation of PIH/TIH materials may have the letter “I” stenciled in place of the letter “W”; e.g., DOT-105J500I, DOT-105J600I, or DOT-112J600I. The letter “I” indicates interim design standards for a PIH/TIH tank car authorized by DOT during this period. DOT Docket HM-219-C prescribes that tank cars meeting the “I” standards will become DOT-105H500W, DOT-105H600W, or DOT-112H500W, respectively, at the next qualification, but not later than December 31, 2027. More information on these requirements is found in Section 5, Pressure Tank Cars.

- 7. Fittings, Linings, and Materials:** For nonpressure tank cars, the numeral following the W will indicate the tank’s material of construction, requirements for insulation or interior lining, and options for a bottom outlet or bottom washout. For tank cars constructed of aluminum, the W will be prefaced by the letters AL. Class-117 tank cars do not have a numeral following the W.

Tank Car Designator Table

Designator	Tank Material	Bottom Outlet	Bottom Washout
Nonpressure tanks			
ALW1	Aluminum	Optional	Optional
ALW2	Aluminum	No	Optional
W1	Carbon steel	Optional	Optional
W2	Carbon steel	No	Optional
W3	Carbon steel (insulated)	Optional	Optional
W4	Carbon steel (insulated)	No	No
W5	Carbon steel (elastomer lined)	No	No
W6	Alloy (stainless) steel	Optional	Optional
W7	Alloy (stainless) steel	No	No
Cryogenic tanks			
W9	Outer tank: AAR TC-128 Grade B normalized carbon steel (minimum 9/16 th inch thick)	No	No

Age/Life Limits – There is no life limit on a tank car tank if it conforms to both the federal regulations and the AAR requirements. An underframe built prior to July 1, 1974, has an AAR life limit of 40 years, unless it has received extended service status. Underframes since July 1, 1974, have an AAR life limit of 50 years.

Note: Underframes may be “continuous” or “stub sill”; refer to “Center Sill” and “Stub Sill Tank Car” in Section 8 for additional information.

Tank Cars Registered by Class Number for Use in North America

<u>Class Number</u>	<u>Number of Tank Cars</u>
DOT/TC 111	200,788
DOT/TC 117	87,619
AAR 211	68,393
DOT/TC 112	62,836
DOT/TC 105	22,194
DOT/TC 120	1,193
DOT/TC 113	369
DOT/TC 115	256
AAR 206	85
DOT/TC 114	82
AAR 204	42
Total	443,857

Note: Data accurate as of April 1, 2022.

Rail Car Orientation Diagram

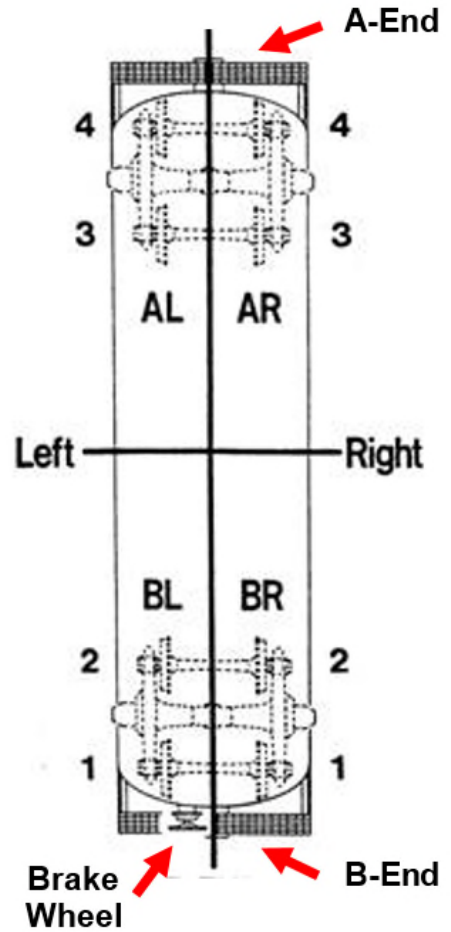

Section 2: Tank Car Safety Systems

Tank cars are equipped with various devices and safety systems to protect the tank and fittings from damage due to overpressure during an accident or severe impact. These devices and safety systems, discussed below, include pressure relief devices (PRDs), coupler vertical restraint systems (double-shelf couplers), tank head puncture-resistance systems (head shields), thermal (fire) protection systems, discontinuity protection (skid protection), and protective housings.

Pressure Relief Devices (PRDs): Per DOT regulation, single-unit tank cars transporting Division 6.1, Packing Group (PG) I and II (poisonous/toxic) materials, Class 2 (compressed gas), Class 3 (flammable liquid), and Class 4 (flammable solid, spontaneously combustible, or dangerous when wet) materials must have reclosing PRDs. However, tank cars built before January 1, 1991, and equipped with a nonreclosing PRD may be used to transport Division 6.1, PG I or II materials or Class 4 liquids, provided the materials are not poisonous (toxic) by inhalation. Refer to subsection titled “Pressure Relief Devices”, page 16, for more information on PRDs.

Coupler Vertical Restraint Systems: Tank cars are equipped with double-shelf couplers. The function of the top and bottom shelves is to prevent couplers from separating in a derailment or over-speed impact, thus reducing the probability of adjacent tank car head punctures in a derailment or over-speed impact.

Tank Head Puncture-Resistance Systems: Tank cars transporting Class 2 (compressed gas) materials and those constructed of aluminum or nickel plate used to transport hazardous materials/dangerous goods and Class-117 tank cars must have a system capable of sustaining, without the loss of lading, coupler-to-head impacts of 18 mph. This is usually accomplished by the installation of separate head shields or full-head tank jackets made of 1/2-inch-thick steel on each end of the tank car.

On some insulated tank cars, i.e., Class-105 pressure tank cars, tank head protection is provided by a combination of the thickness of the tank heads, the insulation system, the gauge (thickness) of the head jacket, and the stand-off distance between the jacket and the tank head.

Thermal Protection Systems: Single-unit tank cars (except Class-113 cryogenic liquid tank cars) transporting Class 2 (compressed gas) materials and Class-117 tank cars must be equipped with a thermal protection or insulation system that provides sufficient thermal resistance so that there will be no release of any lading, except through the PRD, when subjected to a pool fire for 100 minutes or a torch fire for 30 minutes.

Note: The term “pressure relief devices” (PRD) is used by the Department of Transportation and Transport Canada; however, the AAR Specifications for Tank Cars uses the term “safety relief devices” (SRV). The two terms are synonymous, but the term “pressure relief devices” (PRD) will be used in this document.

Double-Shelf Couplers



Head Shield



Bottom Discontinuity Protection Systems: Depending upon the commodity being transported and the projection distance (distance of fittings) from the shell, tank cars equipped with bottom fittings, sometimes called bottom discontinuities (including bottom outlets, bottom washouts, sumps, and blind flanges) must have these fittings protected from being sheared off or otherwise damaged in the event of a derailment or by other impact that could result in the loss of lading. Bottom fittings protection may be accomplished by mounting the valve operating mechanism inside the tank and/or by applying protective skids to the bottom of the tank.

Bottom Discontinuity Protection (Skid)



Continuation of the valve assembly below the tank shell or skid must be designed so that it will fail without damaging the valve, causing a release of product. This is accomplished by incorporating a shear/breakage groove in the valve body or sizing the bolts attaching the valve extension to have low-shear strength.

Protective Housing



Top Fittings Protection: Pressure tank cars are required to have a protective housing bolted to the pressure plate. Top fittings on Class-117 tank cars and nonpressure tank cars in sulfuric acid service must also be protected. Depending upon the date when ordered for construction, nonpressure tank cars transporting a Packing Group I or II material must have top fittings protection. (See Section 4, Nonpressure Tank Cars, for additional information.) Some tank cars may have similar protective skids to protect top fittings.

Protective Skids



Pressure Relief Devices

Pressure relief devices (PRDs) are fittings designed to protect a tank from internal pressure or vacuum in excess of specified settings. Conditions that may cause a PRD to function include the exposure of the tank car to fire, hydrostatic pressure created within a tank overloaded by volume, chemical (exothermic) reaction of the lading in the tank that builds up pressure (such as polymerization), and/or an over-speed impact that results in a pressure spike due to the surge action of the liquid.

In addition to devices that relieve internal pressure, nonpressure tank cars may be equipped with a device to prevent a vacuum from forming within the tank. In general, there are two categories of PRDs:

1. Reclosing devices, such as pressure relief valves (PRVs), and
2. Nonreclosing devices (rupture disc devices) commonly called safety vents.

On nonpressure and pressure tank cars, the PRDs are located on the top of the tank; on cryogenic liquid tank cars, the PRDs are located in closed compartments or cabinets containing the loading and unloading equipment, typically mounted on the sides or on one end of the car.

Note: When used in this Field Guide, the term "safety vent" is interchangeable with "rupture disc device" or "nonreclosing pressure relief device."

Pressure relief valves (PRVs) are spring-loaded, reclosing PRDs designed to open at a set pressure to relieve excessive pressure within the tank. They then automatically reclose after normal conditions are restored. A tank car may be equipped with multiple PRVs to provide the necessary flow capacity for the commodity. (See pages 17 to 18 for examples of PRVs.)

Reclosing Pressure Relief Valves for Nonpressure Tank Cars

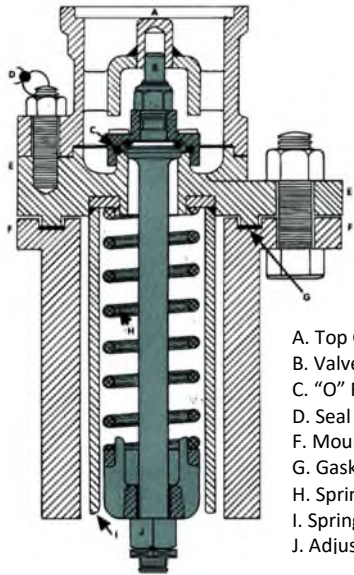

- A. Top Guide
- B. Valve Stem
- C. "O" Rings
- D. Seal
- F. Mounting Flange
- G. Gasket
- H. Spring
- I. Spring Guide
- J. Adjusting Nut

Internal Valve

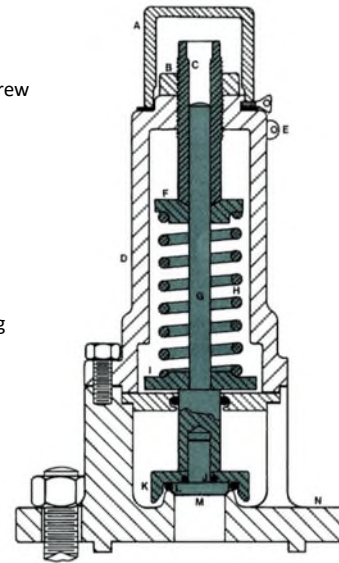

- A. Cap
- B. Top Nut
- C. Adjusting Screw
- D. Top Guide
- E. Seal
- F. Follower
- G. Stem
- H. Spring
- I. Guide
- J. Plug :o: Ring
- K. Retainer
- L. Seat "O" Ring
- M. Plug
- N. Body

External Valve

© Copyright, General American Transportation Corporation; reprinted with permission

Note: Similar appearing valves may be found on pressure tank cars.



Courtesy of Midland Manufacturing Co.



"Constant Force Spring" Pressure Relief Valves



Valve with debris / bee screen

Teflon® coated for corrosive service

Courtesy of Kelso Technologies, Inc.

Reclosing Pressure Relief Devices for Pressure Tank Cars

Pressure Relief Valve



**“REGO 8890-Series”
Pressure Relief Valve**
Courtesy of TransQuip USA.

Combination Pressure Relief Devices



**“Crosby JQ” Chlorine
Combination Pressure
Relief Device**
Courtesy of Salco Marketing, LLC.



**Chlorine Combination
Pressure Relief Device**
Courtesy of Midland
Manufacturing.

Safety vents are nonreclosing pressure relief devices equipped with a rupture disc designed to burst at a certain pressure to relieve pressure. If the disc bursts, the device remains open until the disc is replaced. (See page 19 for examples of safety vents.)

Rupture discs are made from plastic/composite materials or a metal body (usually stainless steel) incorporating an elastomeric-type membrane. Rupture disc devices, instead of PRVs, are typically used on tank cars transporting corrosive materials (such as sulfuric acid) and other materials that may have properties that would be detrimental to the components of a PRV.

Safety vents are also used on tank cars transporting nonregulated commodities, such as corn syrup and clay slurry, and in combination with other PRDs on tank cars transporting cryogenic liquids, such as ethylene, argon and oxygen.

Nonpressure tank cars in regulated commodity service that are equipped with a rupture disc device must have a surge pressure reduction device that, by design, reduces the internal surge pressures at the pressure relief device interface. Such devices are not required for molten sulfur, acrylamide and elevated temperature materials.

Combination PRDs incorporate a nonreclosing device, such as a breaking pin or rupture disc, in series with a spring-loaded reclosing pressure relief valve. The PRV must be outboard of the nonreclosing device (breaking pin or rupture disc). The breaking pin or rupture disc must be designed to fail at a pressure higher than that of the spring-loaded portion of the device. Thus, if internal pressure causes the pin or disc to fail, the spring-loaded portion will open. (See Chlorine Combination PRVs on page 18 above.)

Combination PRDs are typically used on high-hazard PIH/TIH materials, such as chlorine. Combination PRDs utilizing a rupture disc are required to be equipped with a device to detect any accumulation of pressure between the disc and the spring-loaded valve. The device must be a needle valve, try cock, or telltale indicator, which must remain closed during transportation.

Nonreclosing Pressure Relief Devices (Safety Vents) (Aka “Rupture Disc Devices”)

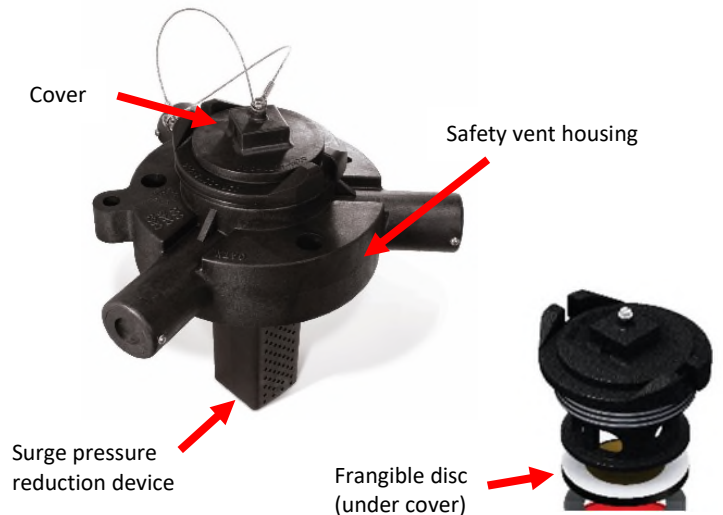
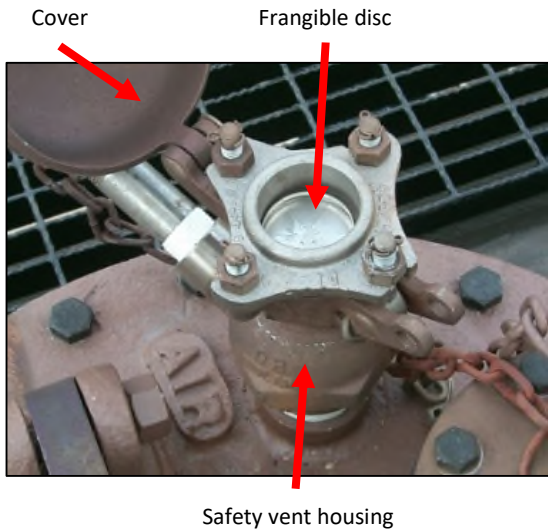

Flexible Liquid Eduction Tubes



Courtesy of Kelso Technologies, Inc.



Courtesy of Salco Products, Inc.

Surge Pressure Reduction Devices



Vacuum-relief valves (also called vacuum breakers) are applied to some nonpressure tank cars to admit air into the tank to prevent excessive internal vacuum that may result in a collapse (implosion) of the tank. This danger exists during closed-system unloading operations using pumps, where the tank is not vented to allow air to enter or, in extreme cases, where an empty tank is subjected to wide temperature variations (hot to cold); e.g., steaming or steam-cleaning a tank car.

Vacuum-relief valves are typically set at negative 0.75 psig or lower. A vacuum-relief valve should not be depressed to determine if there is pressure in the tank, because doing so may dislodge the O-ring seal causing the device to leak.

Vacuum Relief Valves



Courtesy of Midland Manufacturing Co.



Courtesy of Salco Products, Inc.



Courtesy of Kelso Technologies, Inc.



Courtesy of TransQuip USA

Regulating (regulator) valves (called a pressure control device for cryogenic liquid tank cars) are required on pressure tank cars transporting carbon dioxide and nitrous oxide, and cryogenic liquid tank cars. These spring-loaded PRDs, with start-to-discharge pressures lower than the other PRDs (a pressure relief valve and a safety vent), are intended to maintain internal pressure (through auto-refrigeration) by venting vapor during transportation. Such venting is normal in transportation. Tank cars equipped with these devices must be stenciled “**REGULATING VALVE(S) VENTING NORMAL**” on both sides.

Breather vents (also called continuous vents) are devices equipped with a permeable disc, such as pumice stone or a plastic-type membrane. Breather vents are typically applied to nonpressure tank cars transporting hydrogen peroxide solutions to prevent pressure buildup within the tank by allowing the venting of oxygen, which is generated as the material naturally decomposes.

Totally contained commodities are commodities like corn syrup that have been authorized by the AAR Tank Car Committee to be shipped in tank cars not equipped with PRDs. Such tank cars must be stenciled with an AAR specification (a DOT Special Permit is required for DOT specification tank cars.) Further, tank cars must be marked with the name of the commodity it is carrying in minimum 4-inch high lettering and the words “**NO PRESSURE RELIEF DEVICE**” in minimum 2-inch high lettering beneath the name of the commodity.

Pressure Relief Device Settings

For nonpressure and pressure tank cars, governmental regulations prescribe that the start-to-discharge (STD) pressure of a reclosing PRD may not be lower than 75 psig or exceed 33 percent of the tank’s minimum burst pressure. For example, a tank car with a 300 psig tank test pressure (750 psig minimum burst pressure), must have the pressure relief valve’s STD set between a minimum of 75 psig and a maximum of 247.5 psig (33% of 750 psig).

A reclosing valve must have a vapor-tight pressure (VTP) of at least 80 percent of the STD pressure. For example, the minimum VTP for a 75 psig valve would be 60 psig, and the minimum VTP for a 247.5 psig valve would be 198 psig.

Tanks built prior to October 1, 1997, having a minimum burst pressure of 500 psig or less may be equipped with reclosing valve(s) having an STD pressure of no less than 14.5 percent of the minimum burst pressure, but no more than 33 percent of the minimum burst pressure. For example, on a tank with a 60 psig tank test pressure (240 psig) minimum burst pressure, the pressure relief valve must be set between 38.8 (35) and 79.2 (80) psig.

For a nonreclosing safety vent, the rupture disc must be designed to burst at a pressure equal to the greater of either 100 percent of the tank's test pressure or 33 percent of the tank's burst pressure. For example, on a tank car with a 100 psig tank test pressure (500 psig minimum burst pressure), the disc must burst at the greater of 100 psig or 165 psig (33% of 500 psig); therefore, the disc must be designed to burst at 165 psig.

For a combination pressure relief device/valve, the breaking pin must be designed to fail or the rupture disc burst at the pressure prescribed for a reclosing PRD or PRV. Further, the reclosing PRV must be set to discharge at a pressure not greater than 95 percent of the STD pressure. For example, on a tank car with a 500 psig tank test pressure (1250 psig minimum burst pressure), the breaking pin must fail or the rupture disc must burst between 75 and 412.5 psig, and, depending upon the pin or disc's fail point, the reclosing valve must be set to discharge between 71.25 and 391.9 psig.

The type of PRD and the start-to-discharge (STD) pressure of a reclosing pressure relief device or the burst pressure of a rupture disc or breaking pin (in psi) must be applied to the tank's qualification stencil (see page 24). When a rupture disc or breaking pin is used in a combination pressure relief device/valve, the pressure shown is that of the rupture disc or breaking pin.

Tank cars transporting carbon dioxide and nitrous oxide are equipped with three types of PRDs: (1) a reclosing PRV having a STD pressure not exceeding 75 percent of the tank test pressure, (2) a nonreclosing safety vent designed to burst at a pressure less than the tank test pressure, and (3) two regulating valves set to open at a pressure not to exceed 350 psig on a 500 psig test pressure tank or 400 psig on a 600 psig test pressure tank. In addition, the final discharge of each PRD must be piped outside of the protective housing. **Under no circumstances should these discharge pipes be plugged or otherwise blocked.**

Cryogenic liquid tank cars transporting atmospheric gases are equipped with one or more pressure relief valves, safety vents/rupture disc device, and regulating valves. The regulating valve is normally set to limit internal pressure to no more than 25.3 psig under ambient temperature conditions. Some tank cars may have a second safety vent/rupture disc device in series with the first. They are connected to the tank by means of a crossover valve so that only one safety vent/rupture disc device is on-line at a time.

Note: Carbon dioxide tank cars are loaded between 200 and 215 psi pressure, with commodity temperature of minus 16 to minus 20 degrees F. These tank cars have 5 inches of urethane foam insulation, which provides approximately 8 to 10 days' transport time before the commodity warms up. If pressure builds in a 500 psig test pressure tank, the first regulator valve vents at 340 psi. The second regulating valve will vent at 350 psi. If pressure continues to increase, the safety relief valve will open at 375 psi. If the commodity temperature continues to increase, the rupture disk will open at 486 psi. If a rupture disc fails, the liquid will start turning to dry ice when the pressure falls below about 60 psig. Regulating valves create a light hissing sound typically noticeable within one to two car lengths. A venting PRV will be noticeable within 5 to 10 car lengths. An open vent can be heard from greater distances.

Section 3: Tank Car Stenciling and markings

There is a considerable amount of information required by DOT, TC, and/or AAR to be stenciled or marked on the exterior of a tank car. There are standards as to the location and size of the required stenciling.

The information most useful is the tank car’s reporting mark (also called initials) and the car number. The reporting mark, usually three to four letters, identifies the car’s owner (marks ending with an X denote that the car is not owned by a railroad) and is followed by up to six digits, e.g., AARX 332621. The reporting mark and number are the tank car’s unique identifier and are required to be marked on each side of the car to the far left of center and in the center of each end.

Many tank cars are also marked with the reporting mark and number on the top of the car and/or diagonally positioned on the ends. In an emergency, you may identify the contents of a car, from a safe distance, by looking up its reporting mark and number on the shipping papers/shipping documents (paper or electronic) or with the use of the AskRail App (see Section 7: Guidelines for Initial Emergency Response for more information).

Stenciled below the reporting mark and number will be the tank car’s load limit (LD LMT) and light weight (LT WT). The load limit is the maximum weight of lading that may be loaded into the tank car. The light weight is the weight of the tank car when empty. The tank’s volumetric capacity, in gallons and liters, is stenciled centered on each end. (The capacity may also be shown in imperial gallons.)

The tank car’s specification is required to be marked on both sides to the far right of center. The following information can be used to identify the type and characteristics of the tank car.

DOT & TC Tank Car Classes:

- Nonpressure Tank Cars: 111, 115, and 117
- Pressure Tank Cars: 105, 109, 112, 114, and 120
- Cryogenic Liquid Tanks Cars: 113

AAR Tank Car Classes:

- Nonpressure Tank Cars: 206 and 211
- Cryogenic Liquid Tank Cars: 204

Nonpressure and pressure tank cars manufactured prior to July 25, 2012, were required to have the specification; material; cladding material (if any); tank builder’s initials; date of original test; and car assembler (if other than the tank builder) permanently stamped into the metal near the center of both outside heads.

Currently, Class-113 cryogenic liquid tank cars are required to have similar information, including additional information, such as, design service temperature, water capacity, in pounds, and tank shell and head thickness stamped into, or displayed on a metal plate applied to, the B-end (the end of the tank car with the hand brake) outer jacket/shell.

Tank cars manufactured after July 25, 2012, are required to display two identical permanent identification (ID) plates made of corrosion-resistant metal mounted diagonally on the inboard surfaces of the right side (AR) and left side (BL) body bolster webs. The following information is required to be shown on the ID plates: the car builder’s name and serial number; the AAR Certificate of Construction (CofC) number; tank shell/head material; insulation/thermal protection materials and thickness; underframe/stub-sill type; and date built. Tank cars built before July 2, 2012, may have the identification plates instead of, or in addition to, the head stamping.

Identification Plate Format	
Car builder’s name	Allied Tank Car Co
Builder’s serial number	2021 – 01110
Certificate of construction/exemption	AO10209-1234
Tank specification	DOT-117A100W
Tank shell material/head material	TC128 GR B NORM
Insulation materials	Ceramic Fiber/Fiberglass
Insulation thickness	0.5 inch/3.0 inch
Underframe/Stub sill-type	RPM-101
Date built	Dec 2021

Tank cars built before July 2, 2012, may have the identification plates instead of, or in addition to, the head stamping.

When a modification (e.g., retrofitting a Class-111 tank to a Class-117) changes any of the information on the ID plate, an additional variable identification plate must be installed that includes the “AAR Number” (AAR CERT NO) assigned to the modification, items that were modified, and the month and year of modification.

Other information is required to be stenciled on both sides of the tank car near the specification marking on a “qualification stencil”; e.g., required periodic inspections and testing of the tank, PRDs, interior heater system, and interior lining/coating. The stencil will also include the due dates for next inspections and tests.

At the time of construction, tank car tanks are subject to an initial hydrostatic pressure test corresponding to its specification; e.g., the tank test pressure for a specification DOT-111A100W2 tank car is 100 psig. (Some tank car builders test nonpressure cars to 33 percent of the minimum burst pressure; i.e., 165 psig for a tank with a 500 psig minimum burst pressure.)

Prior to 1998, governmental regulations prescribed periodic internal visual inspections, hydrostatic testing of the tank and internal heater coils (if so equipped), and testing of the PRV. Beginning in 1998 (for tank cars without metal jackets) and 2000 (for tank cars with a metal jacket or thermal protection system), all single-unit tank cars (other than Class-113 cryogenic liquid tank cars) used to transport hazardous materials/dangerous goods became subject to periodic “continuing qualification” inspection and testing requirements in lieu of periodic hydrostatic retesting.

The frequency of continuing qualification inspections is based on whether or not the tank car transports commodities that are corrosive to the tank, and whether or not the tank has an interior lining or coating. By regulation, qualification intervals for the tank may not exceed 10 years; for the service equipment, qualification intervals are 5 or 10 years, unless a greater period is approved by the FRA. The current periodic qualification inspections include the following:

- Internal and external visual examinations of the tank
- Structural integrity inspections of various tank welds
- Tank thickness tests
- Safety system inspections, including thermal, head and skid protection, reclosing PRD, and service equipment (valves and fittings)
- Marking inspections
- Lining and coating inspections
- Leakage pressure tests

In addition, the AAR requires periodic inspections of the tank car’s trucks and coupler/draft gear components (88.B.2 Inspection) and stub sills (Stub Sill Inspection). The qualification/test dates and the due date for the next inspections (year only, in four digits) are recorded on a standardized qualification stencil (measuring 44 11/16 inches by 18 3/4 inches) applied to both sides of the tank. (See example on page 24.)

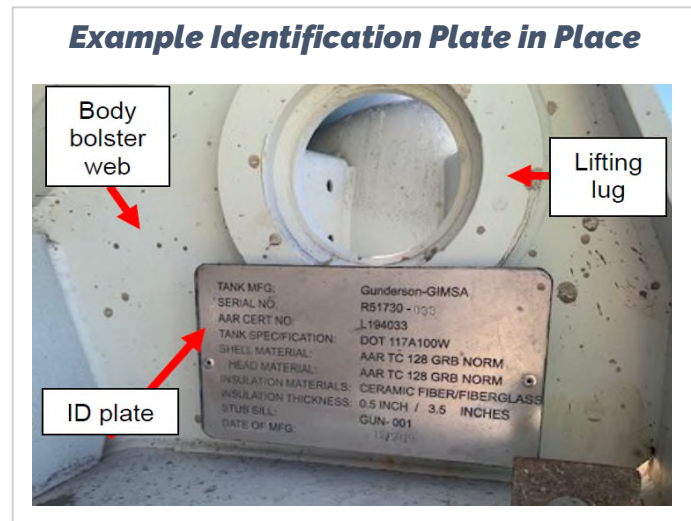

Variable Identification Plate Format

AAR Cert No	AO11222-2345
Insulation Material	1/2-inch Ceramic Fiber
Date of Mfg	10/2020

Tank Car Qualification Stencil

	STATION STENCIL	QUALIFIED	DUE
TANK QUALIFICATION	UTLA	2021	2031
THICKNESS TEST	UTLA	2021	2031
SERVICE EQUIPMENT	UTLA	2021	2031
PRD: VALVE 165 PSI	UTLA	2021	2031
LINING	UTLA	PP	NONE
88.B.2 INSPECTION	UTLA	2021	2031
STUB SILL INSPECTION	UTLA	2021	2031

The date the tank car was built (BLT MO-YR) will be shown on a Consolidated Stencil, or at the BL and AR corners on the sides of the car. (See diagram on page 25.)

In addition to placards and identification number markings, governmental regulations require that the proper shipping name or authorized common name of certain hazardous materials/dangerous goods be marked on each side of the tank car in letters at least 3.9 inches high. For shipments originating in the United States, these commodities are listed in §§172.325(b) and 172.330(a)(1)(ii) of Title 49, Code of Federal Regulations (CFR).

Other markings that may be required on tank cars include:

- Marine Pollutant mark for Marine Pollutants.
- **HOT** for Elevated Temperature Materials.
- **INHALATION HAZARD** for commodities that are poisonous/toxic by inhalation.
- **NON-ODORIZED** or **NOT ODOORIZED** for shipments of unodorized Liquefied Petroleum Gases (LPGs). These markings may appear on a tank car used for both unodorized and odorized LPG.
- **REGULATING VALVE(S) VENTING NORMAL, REGULATING VALVE(S), RELIEF VALVE, or RUPTURE DISC**, as appropriate, over/under the discharge pipe for tank cars in argon, oxygen, carbon dioxide, and nitrous oxide.
- **DOT-SP******* for a tank car operating under the provisions of a DOT Special Permit.
- **SR-****** for a tank car that is operating under the provisions of a Canadian Equivalency Certificate.
- **AAR ST-****** for a tank car that is operating under an AAR Service Trial.
- **EXS** after the reporting mark and number for a tank car authorized for extended service status. Example: BOEX 2016 EXS
- **FRA AIP** near the qualification stencil indicates that a Federal Railroad Administration (FRA) approved alternative inspection program authorizes an extended qualification interval.

Tank cars equipped with bolted and hinged manway covers must be marked with a manway style decal or stencil near the manway. The letters and numerals must be at least 1/4-inch high. Manway style charts, found in Appendix D of the AAR Specifications for Tank Cars and AAR Pamphlet 34, identify manway styles, manway nominal diameter, number of bolts, and gasket dimensions.

Note: The following is an explanation of some of the information found in the qualification stencil.

- **STATION STENCIL:** an alpha code assigned by the AAR to the tank car facility performing the inspection.
- **SERVICE EQUIPMENT:** filling/discharge, venting, safety (other than pressure relief devices), heating, and measuring devices.
- **THICKNESS TEST: LNG RMVL:** Test required when lining is removed.
- **PRD:** indicates the type of pressure relief device applied and its start-to-discharge (STD) or burst pressure.
- **VALVE:** reclosing pressure relief valve.
- **DISC or VENT:** nonreclosing rupture disc device.
- **COMB:** combination pressure relief device (reclosing valve with a rupture disc or breaking pin).
- **NONE:** no pressure relief device (total containment).
- **INT HTRS:** interior heater system. Exterior heater systems do not require requalification.
- **LINING PP:** indicates the lining is applied to maintain product purity, not to protect the tank from the corrosive effects of the lading. PP linings do not require requalification.

Manway Style Marking



Some tank cars are equipped with remote monitoring equipment (RME) to monitor and record or transmit certain data regarding a shipment, such as location (via GPS), lading temperature and/or pressure, leak detection, impact detection, indication of tampering with or opening the protective housing, and loaded or empty status.

Typical Remote Monitoring Devices

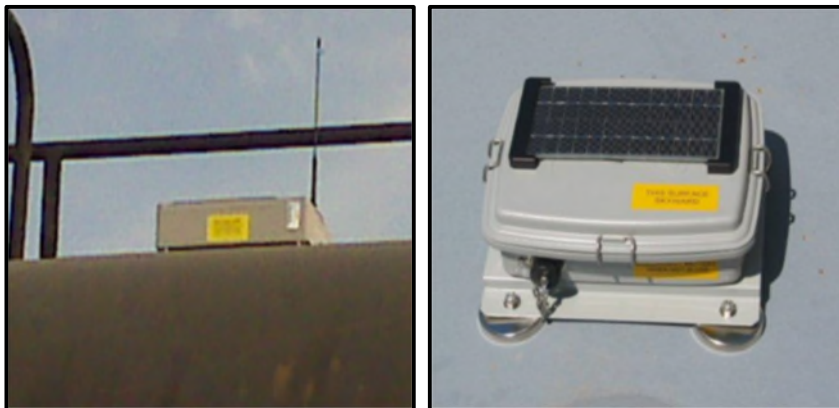

The AAR has established standards regarding the placement of such devices and wiring. Tank cars equipped with RME must display labels or stencils within 12 inches of the sensor, be bright yellow or orange with black lettering, and be at least 2 x 3 inches. The marking must describe the device and provide a telephone number to call for information on the device.

Location of Key Stenciling



- Left Side:**
- REPORTING MARK / NUMBER
 - LD LMT (LB / KG)
 - LT WT (LB / KG)

Consolidated Stencil

Type of air brake valves

DB - 10	DB - 20
---------	---------

Car built date →

BLT 10-16

- Right Side:**
- DOT SP / SR / AAR ST
 - COMMODITY NAME
 - DOT / TC / AAR SPECIFICATION
 - QUALIFICATION PANEL

- Heads:**
- REPORTING MARK / NUMBER
 - CAPY (GAL)
 - CAPY (L)



Note: In November 2017, AAR removed the requirements for display of Consolidated Stencils on freight cars. A tank car's built date (BLT) will be stenciled at the BL and AR corners on the sides of the car in the area near the qualification panel

Section 4: Nonpressure Tank Cars

Nonpressure tank cars (also called “low pressure” or “general service” tank cars in the *2020 Emergency Response Guidebook*), Classes DOT/TC-111, 115 and 117 and AAR-206 and 211, are used to transport a wide variety of liquid and solid regulated (hazardous materials/ dangerous goods) as well as nonregulated commodities. The most common nonpressure tank cars in use today are Class DOT-111 and Class AAR-211.

Class-111 tank cars made of carbon or alloy (stainless) steel are required to have a minimum shell thickness of 7/16 inch, and those made of aluminum are required to have a minimum shell thickness of 1/2 inch (60 psig tank test pressure) or 5/8 inch (100 psig tank test pressure). Regardless of the material of construction, Class-111 tank car tanks with a 60 psig tank test pressure are required to have a minimum burst pressure of 240 psig, and those with a 100 psig tank test pressure are required to have minimum burst pressure of 500 psig.

Class-117 tank cars are designed primarily for the transportation of Class 3 (flammable liquid) materials; and the tanks are required to be constructed of AAR TC-128 Grade B normalized carbon steel, with a minimum thickness of 9/16 inch. The tank test pressure is 100 psig, with a burst pressure of 500 psig. Class-117 tank cars must have a tank head puncture resistance system consisting of full-height head shields at least 1/2-inch thick and a thermal protection system covered by a metal jacket of not less than 11 gauge (approximately 1/8 inch) thick (tank insulation is optional). A reclosing pressure relief device and top fittings must be protected. If equipped with a bottom outlet, the operating handle must be removed before movement, or the valve must be designed with a protection safety system to prevent unintended actuation during train accident scenarios.

Note: Find additional information regarding Class-117 tank cars in Annex A.

Class-211 tank cars are similar to Class-111 tank cars, and, with certain exceptions, must be built in accordance with the applicable DOT/TC specification, e.g., a specification AAR-211A100W1 tank car must be built to the requirements for a specification DOT-111A100W1 tank car. The main differences between an AAR tank car and its DOT/TC specification counterparts are:

- Class-211 tank car tanks require only partial post-weld heat treatment at the time of construction. Class-111 carbon and alloy (stainless) steel tanks and welded attachments must be post-weld heat treated as a unit. Tank car tanks made of aluminum are not allowed to be post-weld heat treated.
- Class-211 tank car tanks constructed of carbon and alloy (stainless) steel do not require radioscopic examination of welded joints; however, welded joints of aluminum tanks must be examined.
- Additional/special fittings on AAR cars to meet user needs.

Most nonpressure cars have a low-profile manway nozzle on top of the tank, equipped with a gasketed hinged and bolted manway cover. The cover is opened for loading/unloading or for access into the tank for maintenance. Other styles of manway covers (such as those on sulfuric or hydrochloric acid tank cars) are semi-permanently attached to the manway nozzle and are equipped with a small gasketed hinged and bolted fill hole with a cover that is opened for loading or unloading.

Loading and unloading fittings are typically located in the general area of the manway and are often enclosed within a hinged combination housing called a protective housing by DOT regulations. Some nonpressure tank cars may be equipped with a protective housing similar to those used on pressure tank cars to provide additional protection for the valves and fittings.

All Class-117 tank cars, and some other nonpressure tank cars, are equipped with a protective housing similar to those used on pressure tank cars to provide additional protection for the valves and fittings.

On nonpressure tank cars, the top-mounted loading/unloading equipment will usually include a 2- or 3-inch liquid eduction line (located along the centerline of the tank). The liquid eduction line consists of a liquid valve (or other closure) and eduction (or siphon) pipe that extends to the bottom of the tank. The eduction pipe may extend into a sump.

A sump is a formed depression (or bowl) in the bottom of the tank where the lading will drain, allowing more complete emptying of the tank.

There may also be a smaller eduction line (typically 1-inch), called an air inlet, used to introduce a compressed gas (e.g., air and nitrogen) to pressurize the tank for unloading through the liquid eduction line. This device may also be used to vent the tank during loading or unloading.

Other fittings may include a vacuum-relief valve, a 1/4-inch sample line, and/or a gauging device (either a magnetic ball style or a fixed-length telltale pipe with a control [needle] valve). The interior of the tank may be equipped with an outage gauge (at the manway nozzle) indicating vacant or vapor space in the tank, usually graduated in inches of outage.

On nonpressure tank cars in some services (e.g., sulfuric acid), the liquid eduction line and air inlet fittings may not have control valves because they are closed with pipe caps, plugs, or blind flanges.

PRDs (reclosing pressure relief valves or nonreclosing rupture disc devices/safety vents) may be attached to the top of the tank on separate nozzles or attached to the manway cover.

Nonpressure tank cars in some corrosive services will often have the manway plate face and fittings flange faces rubber lined. However, due to advances in coating and lining materials, some nonpressure tank cars in corrosive service may have metal-based, hard coated, or hard polymer-lined manway plate or fittings flange faces and components of material suitable for the service.

Nonpressure tank cars may have insulation (typically fiberglass, mineral wool blankets, or foam) applied over the tank and enclosed within a metal jacket. Per regulation, the jacket must be not less than 11 gauge (approximately 1/8 inch) thick.

Jacketed insulation is used to moderate the temperature of the lading during transportation; e.g., to keep the lading cool or warm, depending upon its characteristics and the season of the year or as an aid in heating the product for unloading.

In addition to insulation, some nonpressure tank cars in flammable liquid service have been equipped with thermal protection and Class-117 tank cars are required to have a thermal protection system (insulation is optional).

Jacketed tank cars can be recognized by one or more of these visible indicators:

1. Flashing (shroud or cover) over the body bolster or tank bands.
2. Flat appearance of ends or indented sections on sides of tank car.
3. Rough appearance of visible welds, including lap welds, with welds generally thinner than tank welds.

Clues for Recognizing Jacketed Tank Cars

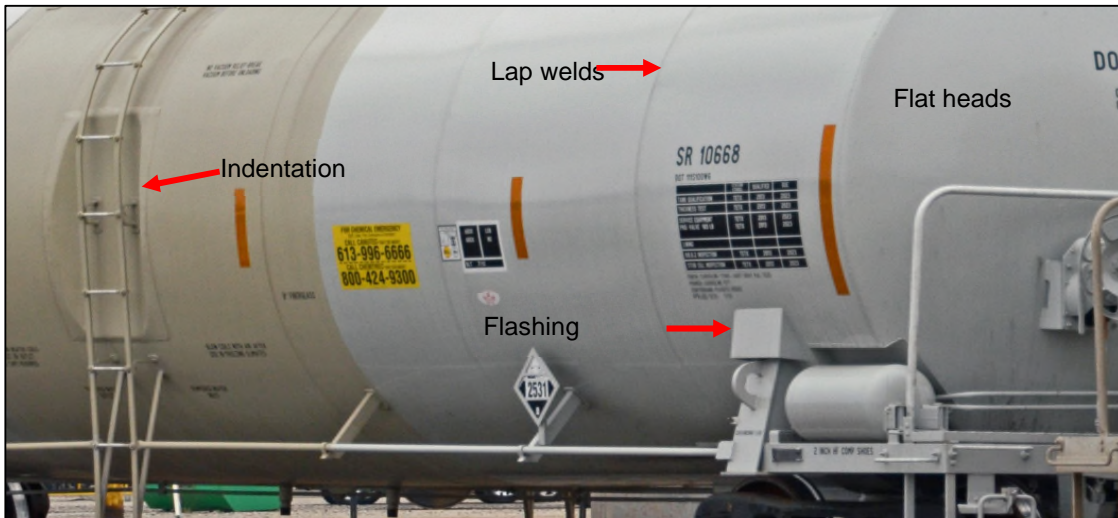

Except for certain specifications, nonpressure tank cars may be equipped with bottom outlet valves for loading or unloading. These valves may be ball, wafer-sphere, or butterfly style valves that are operated from beneath the car. They may also be plug or clapper style valves that are operated from the top of the tank.

The top-operated bottom outlet valve is an internal plug valve that is mounted on the bottom of the tank. The valve is attached to a rod that passes up through the tank and through a stuffing box body on top of the tank. The stuffing box body is equipped with a combination cover and wrench (T-wrench or cone) used to open and close the valve.

Certain specification nonpressure tank cars may be equipped with a bottom washout that can be removed to facilitate cleaning of the tank's interior. It is not used in loading/unloading operations.

Depending upon their projection from the bottom of the tank shell, bottom discontinuities (bottom outlets, blind flanges, washouts, and sumps) applied to stub sill tank cars may be required to have bottom fittings protection.

Typically, this protection is provided by attaching skids to the bottom of the tank to protect the fittings in the event of a derailment. Some nonpressure tank cars are also equipped with skids to protect their top fittings.

Tank cars may also be equipped with interior or exterior heater coils. Prior to unloading, steam, hot water, or hot oil lines are attached to the coil inlets and outlets. As the heating medium circulates through the coils, it heats the liquid or melts solidified ladings, such as phosphorus, sulfur, wax, and asphalts, to facilitate unloading. Interior heater coil inlet and outlet pipes are required to have caps or plugs applied during transportation. Exterior heater coils do not require caps, and the car must be stenciled "EXTERIOR HEATER PIPES – NO INLET OR OUTLET PIPE CAPS REQUIRED". Some nonpressure tank cars are equipped with electric-resistance heater systems in place of heater coils.

Nonpressure single-unit tank cars may be divided into compartments by inserting ellipsoidal heads into the tank shell (heads must be concave to the lading of each compartment) or by joining separately constructed tanks to make a single car structure. Each compartment will have its own loading/unloading fittings and PRD.

Compartments must be identified numerically, beginning with the B-end (the end of the car with the hand brake

wheel) compartment as number 1 and numbered consecutively toward the A-end (the end without the brake wheel).

Note: *Unlike highway cargo tanks, tank car compartments are not constructed by applying interior walls within a single tank. Further, unlike some cargo tanks, tank cars do not have interior baffles to control lading surges.*

Class-115 and Class-206 nonpressure tank cars have an inner container (tank) constructed of carbon steel, alloy (stainless) steel, manganese molybdenum steel, or aluminum. The inner tank is supported within an outer shell (tank, not jacket).

The annular space between the inner tank and outer tank contains insulation. These cars are commonly referred to as tanks-within-a-tank as the outer tank is constructed in the same manner as the inner tank; it is not merely a metal jacket covering an insulated tank.

For Class-115 tank cars, the outer tank may be fabricated of the same materials authorized for inner tanks and must be at least 7/16-inch thick. For Class-206 tank cars, the outer tank must be fabricated from carbon steel. They may be divided into compartments, have a 60-psig tank test pressure, and, in addition to loading/unloading and pressure relief devices, they may be equipped with a bottom outlet and/or bottom washout. These tank cars are normally used to transport temperature-sensitive commodities that require a highly efficient insulation system.

The illustrations on the following pages show typical nonpressure tank cars and their valve and fittings arrangement. Individual tank car arrangements may vary based upon product service and/or the equipment manufacturer. Nomenclature used in some illustrations may not always be consistent with that used in the text of the Field Guide.

DOT/TC-111A100W1 General Service Tank Car



Characteristics:

- Minimum 7/16-inch carbon steel tank
- Jacketed insulation optional
- Top operating platform with manway, pressure relief device, and combination housing containing liquid valve, air valve, and vacuum relief valve mounted on a fittings plate
- Gauging device optional
- Bottom outlet optional

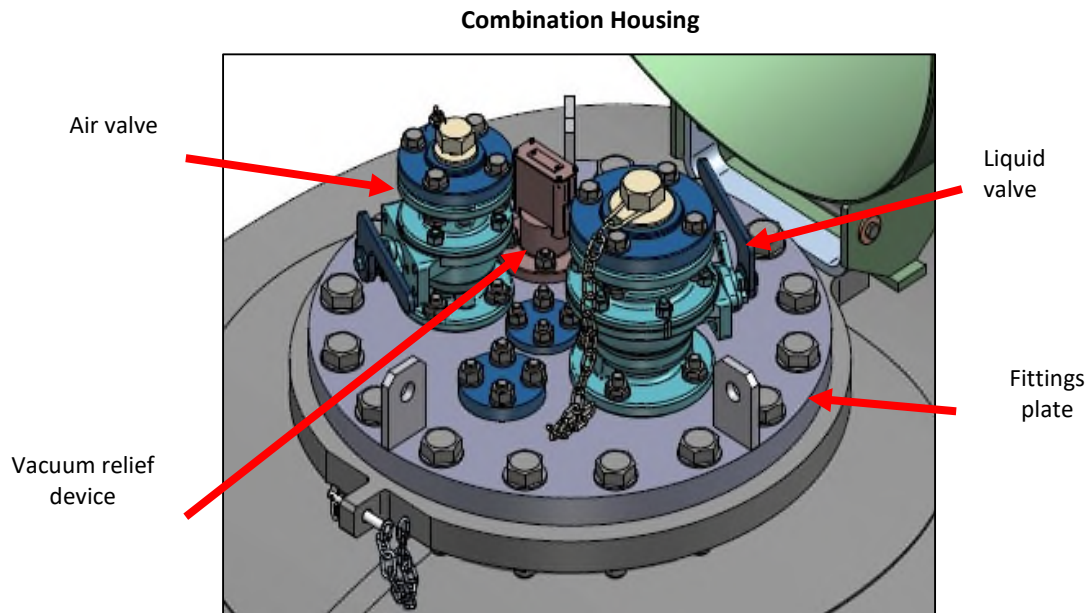

DOT/TC-111A100W1 Tank Car with Protective Housing (Sodium Hydroxide)



Characteristics:

- Minimum 7/16-inch steel tank
- Jacketed insulation optional
- Top operating platform with manway and protective housing containing pressure relief device, liquid valve, and air valve
- Bottom outlet optional
- Interior or external heater coils optional

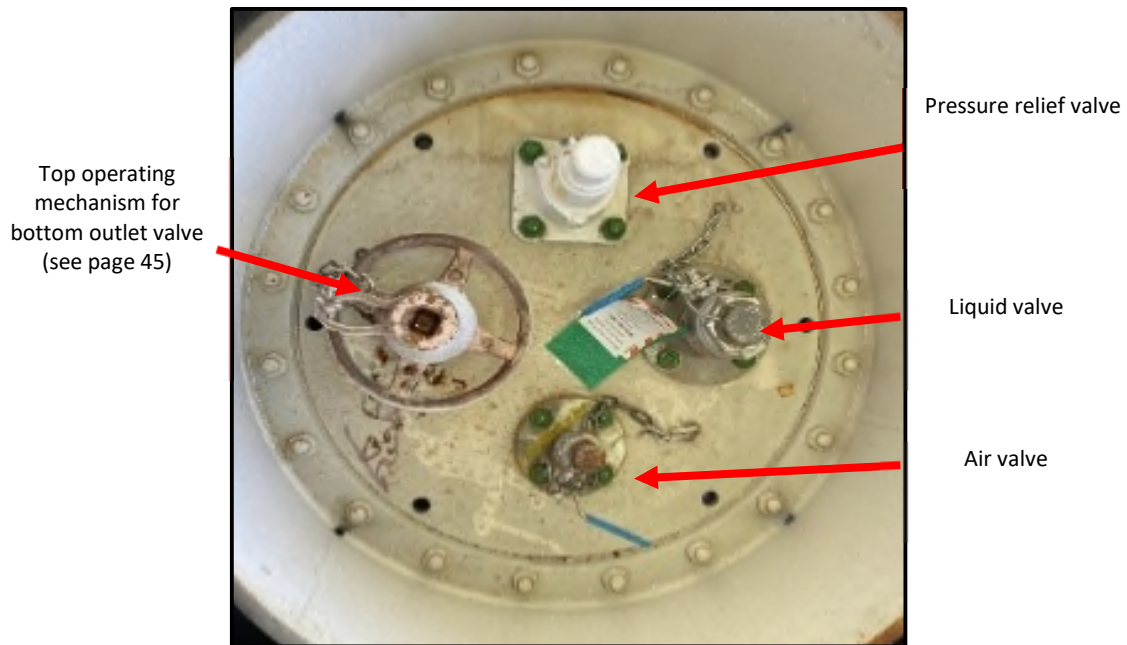

DOT/TC-111A100W1 Tank Car without Protective Housing (Sodium Hydroxide)



Characteristics:

- Minimum 7/16-inch carbon steel tank
- Jacketed Insulation optional
- Top operating platform with manway, pressure relief device, and combination housing containing liquid valve, air valve, and vacuum relief valve
- Bottom outlet optional
- Interior or external heater coils optional

Manway with manway cover

Pressure relief device (valve)

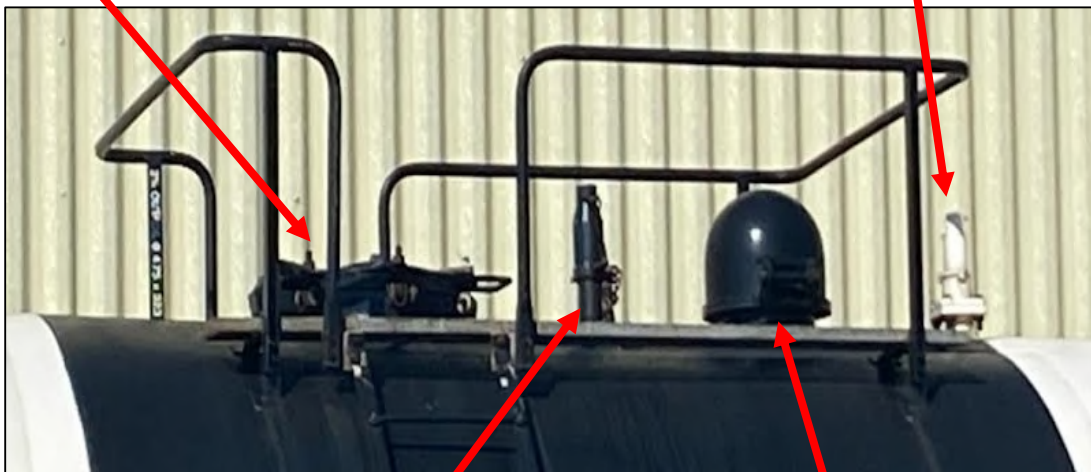

Top operating mechanism for bottom outlet valve

Combination housing (liquid valve, air valve, and vacuum relief valve)

DOT/TC-111A100W2 Tank Car with Protective Housing (Sulfuric Acid)



Characteristics:

- 7/16-inch carbon steel tank
- Top operating platform with manway, pressure relief device, liquid valve, air valve, and fill hole
- Combination housing optional
- Insulation optional
- Bottom outlet prohibited
- Bottom washout optional

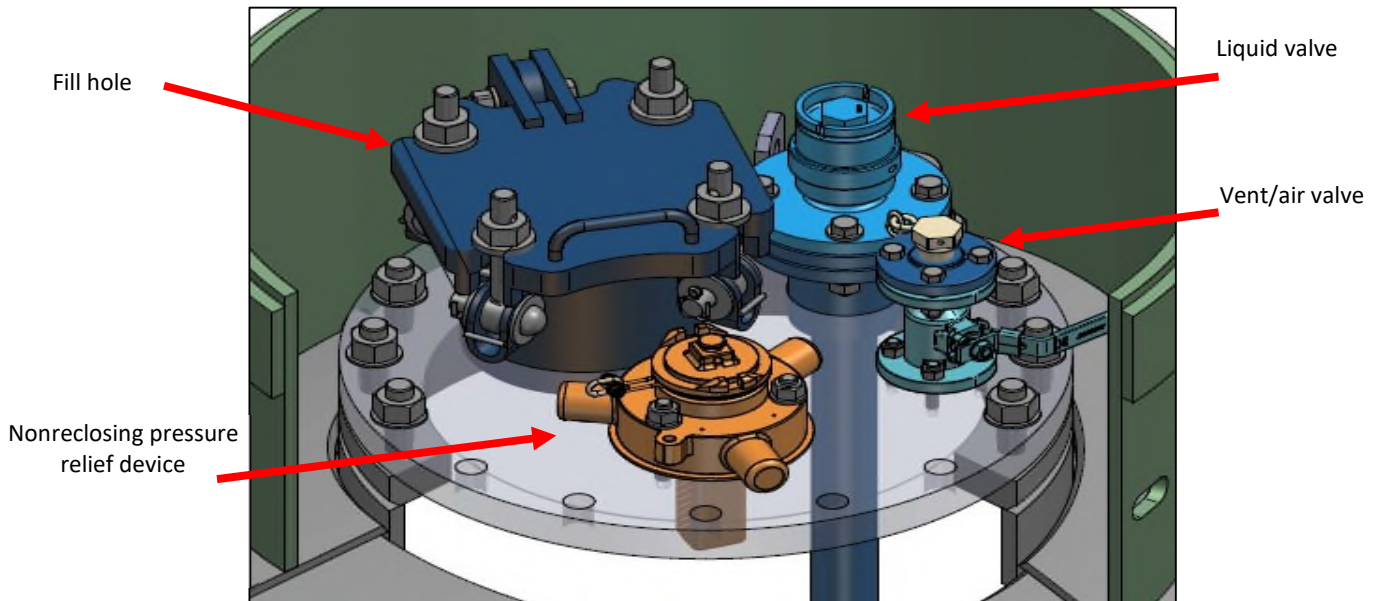

DOT/TC-111A100W2 Tank Car without Protective Housing (Sulfuric Acid)



Characteristics:

- 7/16-inch carbon steel tank
- Jacketed insulation optional
- Top operating platform with manway, pressure relief device (reclosing or nonreclosing), and fittings plate with liquid valve, air valve, and fill hole
- Bottom outlet prohibited
- Bottom washout optional

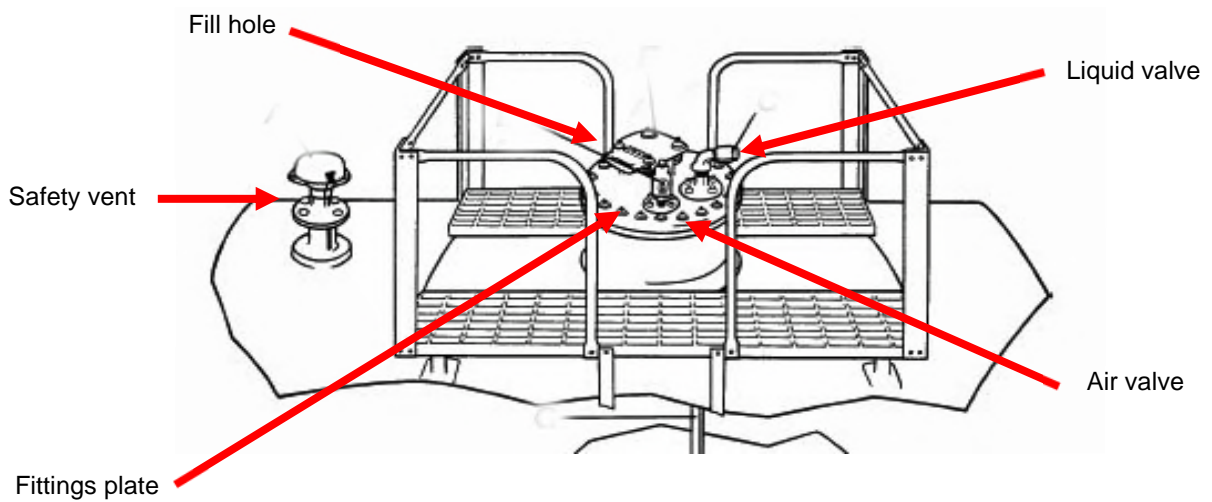

DOT/TC-111A100W5 Tank Car with Protective Housing (Hydrochloric Acid)



Characteristics:

- 7/16-inch carbon steel tank
- Tank lined with acid resistant material (rubber, polyvinyl chloride, or polyurethane)
- Jacketed insulation optional
- Headshields optional
- Top fittings within protective housing (air valve, liquid valve, fill hole, and pressure relief device)
- Bottom outlet prohibited
- Bottom washout prohibited

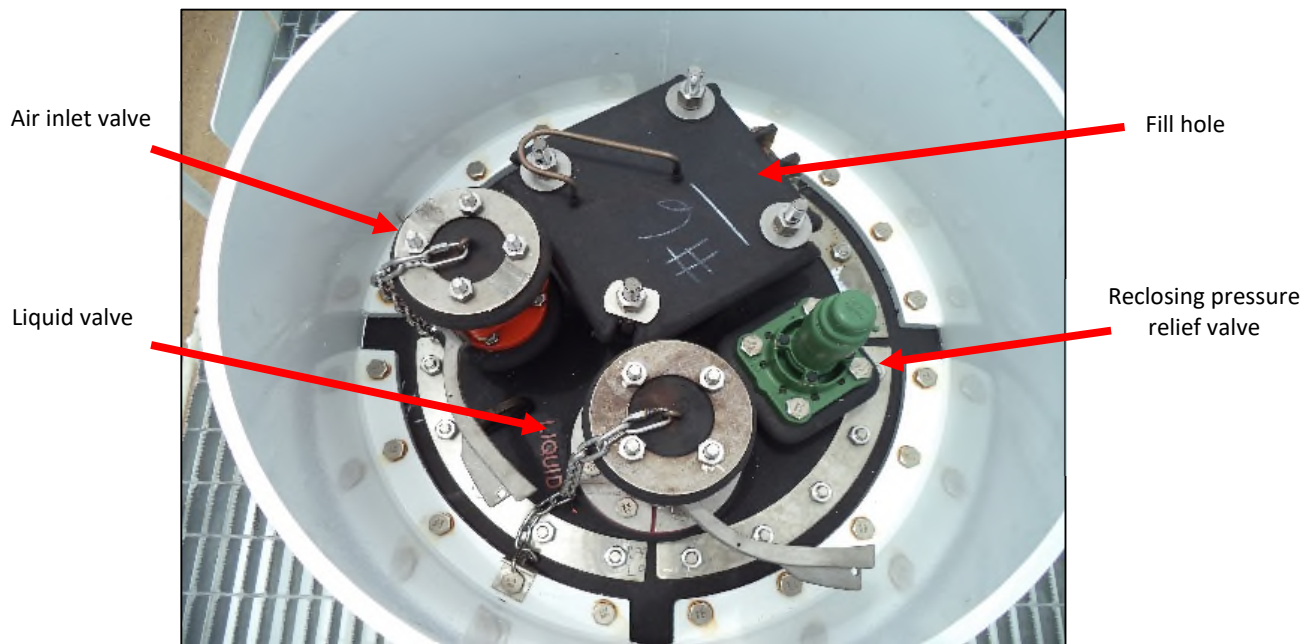

Photographs courtesy of The Chlorine Institute

Manway Arrangements with Different PRD Options for Hydrochloric Acid Tank Cars

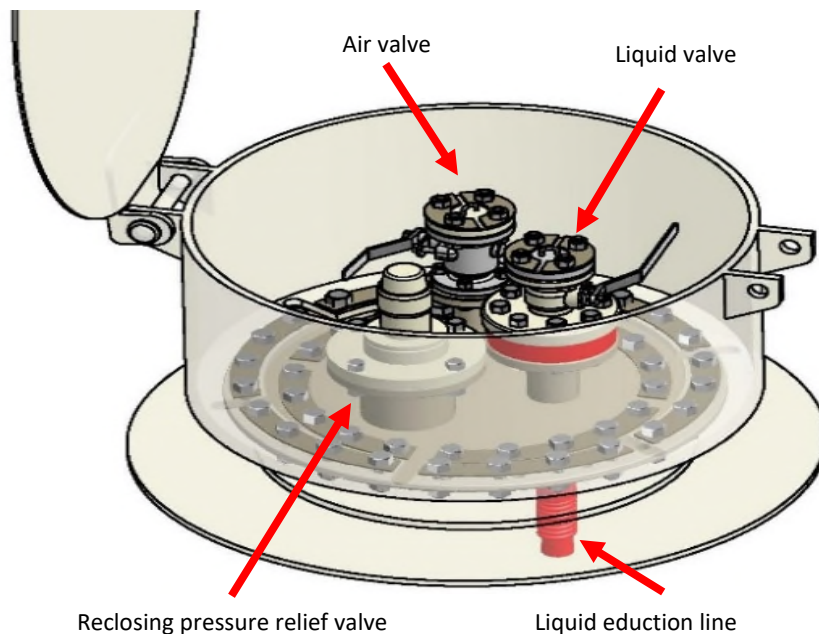

Typical 20-inch HCl Manway

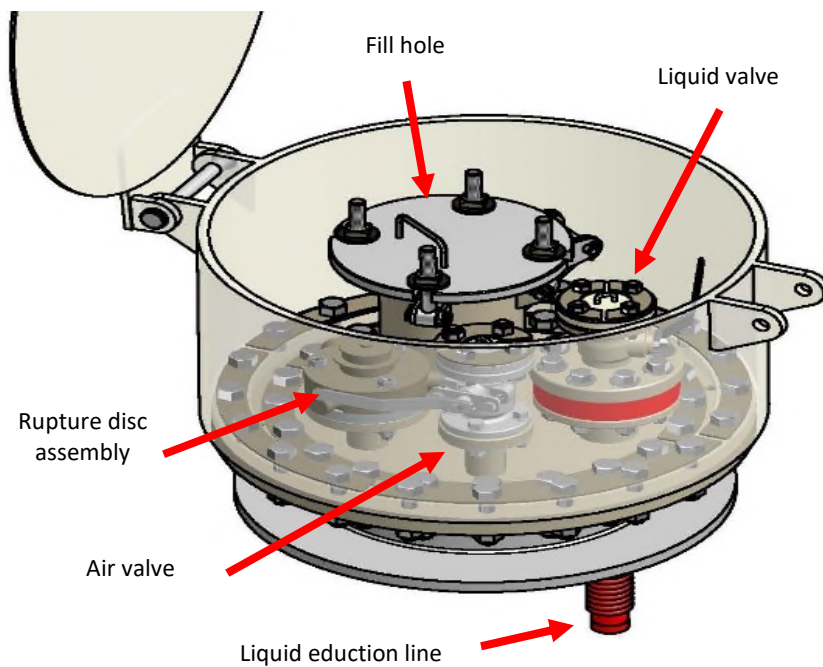

Typical 22-inch HCl Manway

Illustrations courtesy of The Chlorine Institute

DOT/TC-111A100W5 Tank Car without Protective Housing (Hydrochloric Acid)



Characteristics:

- 7/16-inch carbon steel tank
- Tank lined with acid resistant material (rubber, polyvinyl chloride, or polyurethane)
- Jacketed Insulation optional
- Head shields optional
- Top operating platform with manway, pressure relief device, liquid valve, air valve, and fill hole
- Bottom outlet prohibited
- Bottom washout prohibited

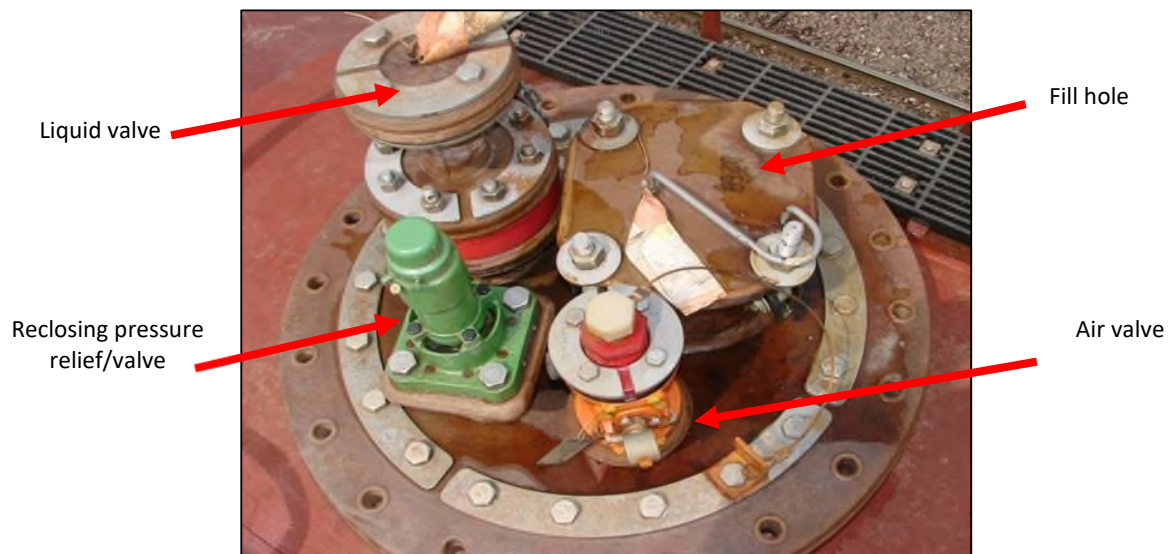

DOT/TC-111A100W6 Tank Car (Hydrogen Peroxide)



Characteristics:

- 7/16-inch alloy (stainless) steel tank
- Jacketed insulation optional
- Head shields optional
- Fittings platform with reclosing pressure relief valve, continuous breather vent, manway, and fittings plate with an air valve and liquid valve attached)
- Bottom outlet optional
- Bottom washout optional

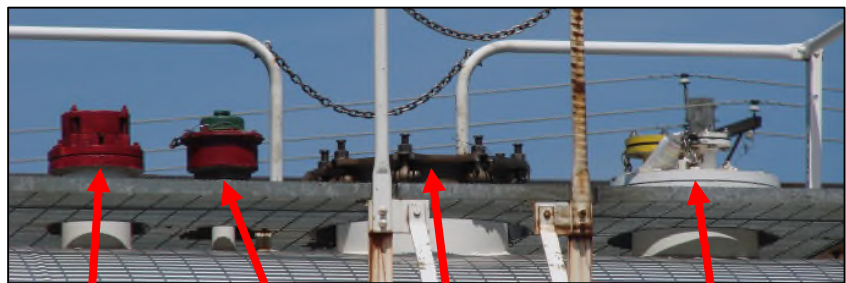

Rupture disc assembly

Continuous breather vent

Manway

Fittings plate with air valve and liquid valve

DOT/TC-111A100W7 Tank Car (Hydrogen Peroxide)



Characteristics:

- 7/16-inch alloy (stainless) steel tank
- Jacketed insulation optional
- Head shields optional
- Fittings platform with reclosing pressure relief valve, continuous breather vent, manway, and fittings plate with an air valve and liquid valve attached)
- Bottom outlet optional
- Bottom washout optional

DOT/TC-111A100W1 (CPC-1232*) Tank Car (Flammable Liquids)



Characteristics:

- AAR TC-128 Grade B normalized carbon steel (min. 1/2-inch thick for non-jacketed tanks and 7/16-inch thick for jacketed tanks)
- Jacketed insulation optional
- 1/2-inch thick half- or full-height head shields
- Reclosing pressure relief valve (PRV)
- Top fittings protection (protective housing)
- Bottom outlet

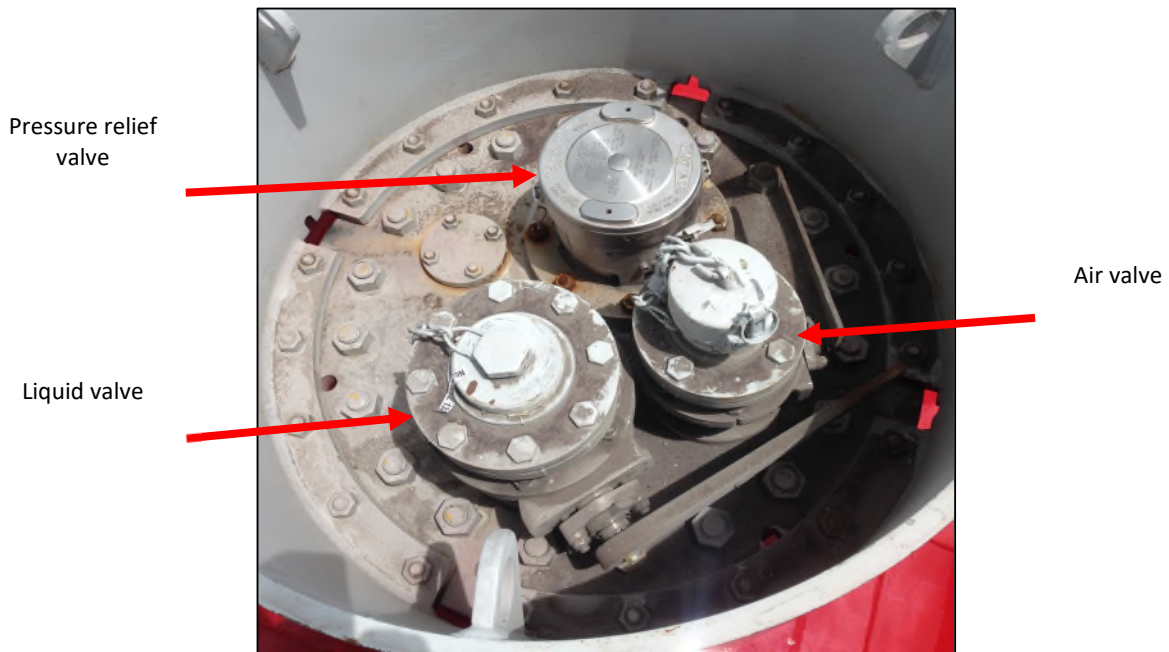

*Note: Referred to as "enhanced 111" tank cars in Canada.

DOT/TC-117R100W Tank Car (Flammable Liquids)



Characteristics:

- Minimum 7/16-inch AAR TC-128 Grade B carbon steel
- 1/2-inch thick full-height head shields built into the jacket
- Jacketed thermal protection
- Reclosing pressure relief valve (PRV)
- Top fittings protection (protective housing) (See sample top fitting arrangements page 42.)
- Bottom outlet with operating handle disengaged or removed during transportation

Variable Identification Plate (See pages 22-23.)



Identification Plate (See pages 22-23.)

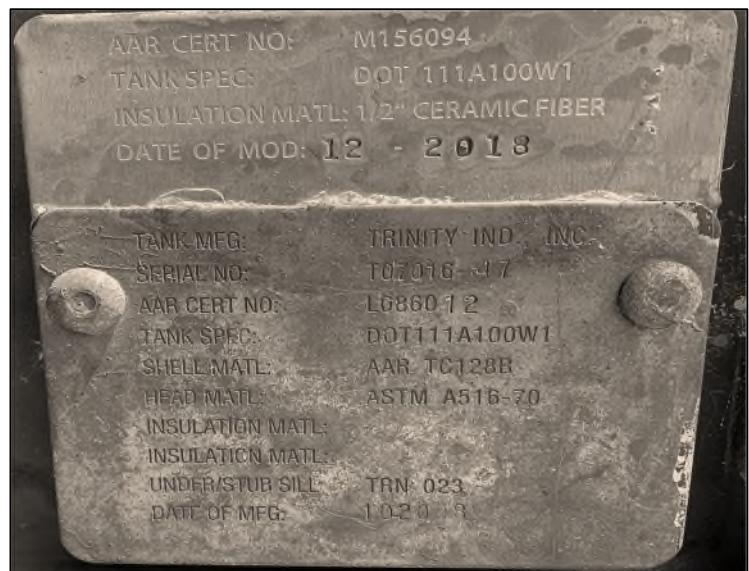

DOT/TC-117J100W Tank Car (Flammable Liquids)



Characteristics:

- Minimum 9/16-inch AAR TC-128 Grade B normalized carbon steel
- Jacketed thermal protection required
- Insulation under the jacket optional
- 1/2-inch thick full-height head shields built into the jacket
- Top fittings protection (protective housing) (See sample top fitting arrangements page 42.)
- Reclosing pressure relief valve (PRV)
- Bottom outlet with operating handle disengaged or removed during transportation

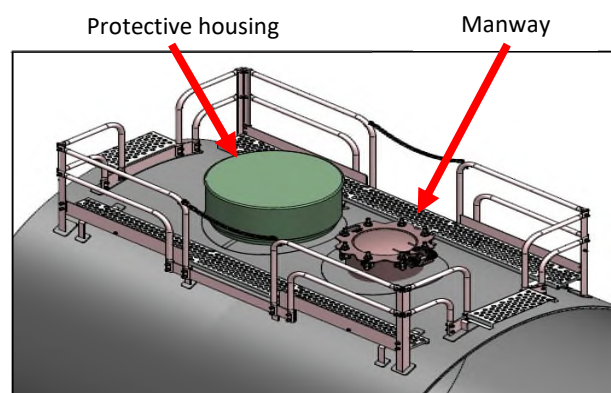
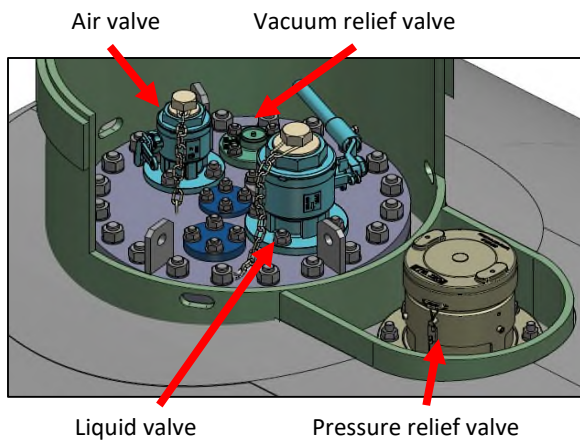
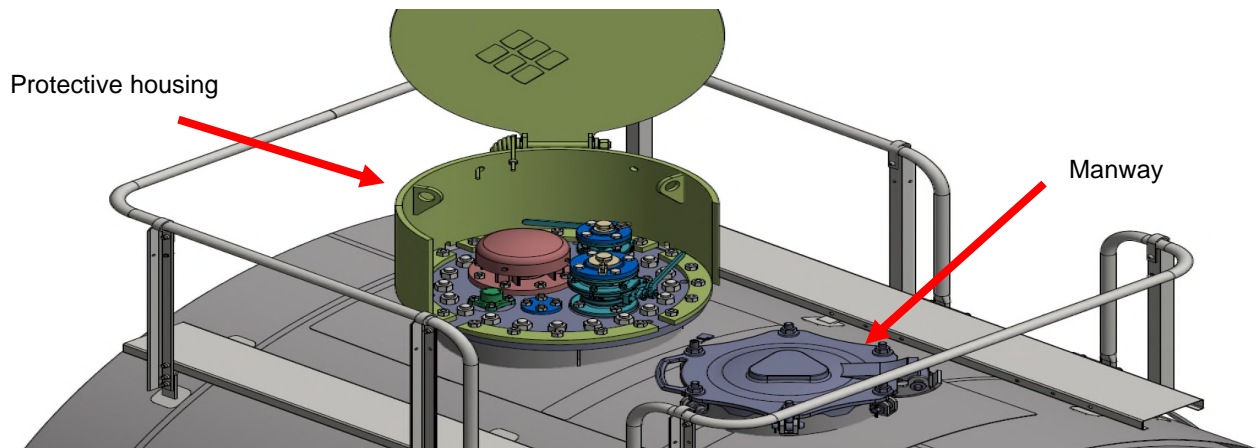

Illustrations courtesy of RSI

Examples of Fitting Arrangements for Class DOT-117 Tank Cars

Note: Fitting arrangements are based on the characteristics of commodities and shipper's differing needs and uses. These arrangements represent the most common; although other arrangements may be found.

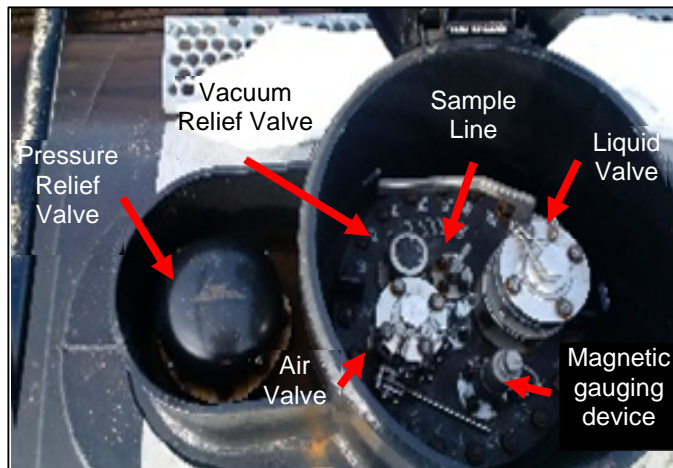
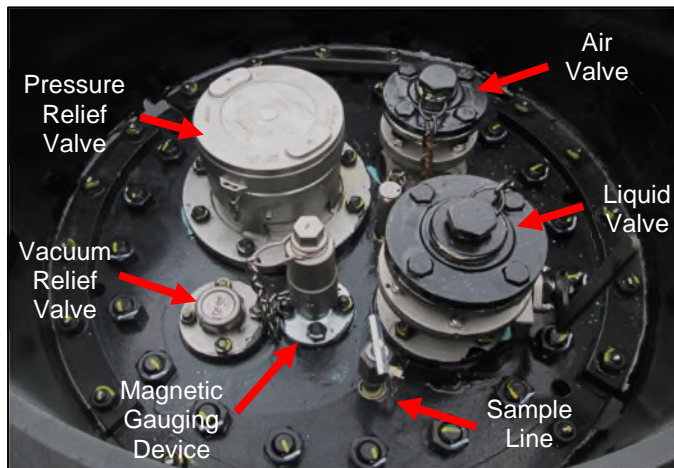

Comparison of Tank Cars for High-Hazard Flammable Liquids

See Appendix A for additional information, including phase-out dates

Requirements / Specification	DOT/TC-111A100W Legacy Tank Car	CPC-1232 Enhanced111	Class DOT-117 Tank Cars		
			117P100W	117R100W	117J100W
Minimum plate thickness - heads and shell	7/16-inch	7/16-inch (jacketed tank) or 1/2-inch (non-jacketed tank) ⁽¹⁾	7/16-inch ⁽²⁾	7/16-inch ⁽²⁾	9/16-inch
Tank material	Steel	⁽²⁾	Steel	Steel	Steel
Normalized	No	Yes	Not required	Optional	Yes
Steel jacket	Some	Some	Yes	Yes	Yes
Thermal protection	No	Not required	Yes	Yes	Yes
Insulation	Optional	Optional	Optional	Optional	Optional
1/2-inch head shields	No	Half or Full	Full	Full	Full
Top fittings protection	No	Yes	Yes	Yes	Yes
Improved bottom outlet handle, if equipped	No	No	Yes	Yes	Yes
Reclosing pressure relief valve (PRV)	Yes	Yes	Yes	Yes	Yes

(1) Heads and shell must be constructed of normalized AAR TC128 Grade B steel or ASTM A516-70 steel (See Annex A.)

(2) Constructed with steel authorized by regulations at time of construction (See Annex A.)

Class DOT/TC-117 Bottom Outlet Operating Mechanism

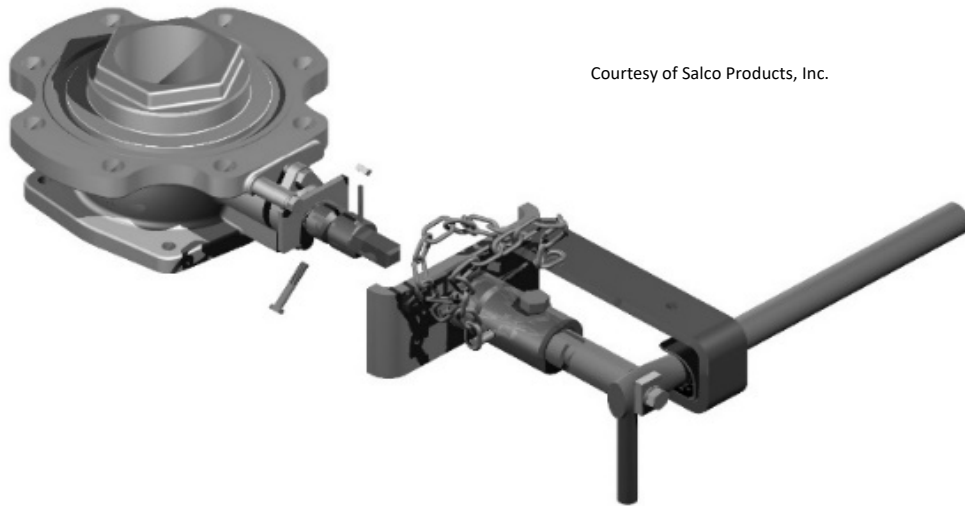

Courtesy of Salco Products, Inc.



Courtesy of Railway Association of Canada.

DOT/TC-Class 111 Multi-compartment Tank Car



Characteristics:

- 7/16-inch steel or 1/2-inch aluminum heads and shell
- Multiple compartments, each built as a separate tank
- Jacketed insulation optional
- Top operating platform for each compartment with manway, pressure relief device, and combination housing with liquid valve, air line, and vacuum relief valve
- Bottom outlet with protective skid for each compartment

AAR-211A100W1 Tank Car (Food Products, Clay Slurry, Low-Hazard Hazardous Materials)



Characteristics:

- Minimum 7/16-inch carbon steel tank
- Jacketed insulation optional
- Top operating platform with pressure relief device and manway
- Optional fittings plate with liquid valve, air valve, and/or vacuum relief valve
- Bottom outlet optional

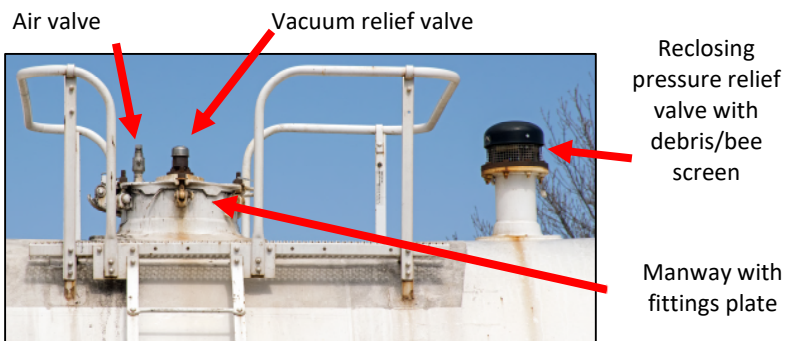

Examples of Nonpressure Tank Car Service Equipment

Top Operated, Bottom Unloading Valves

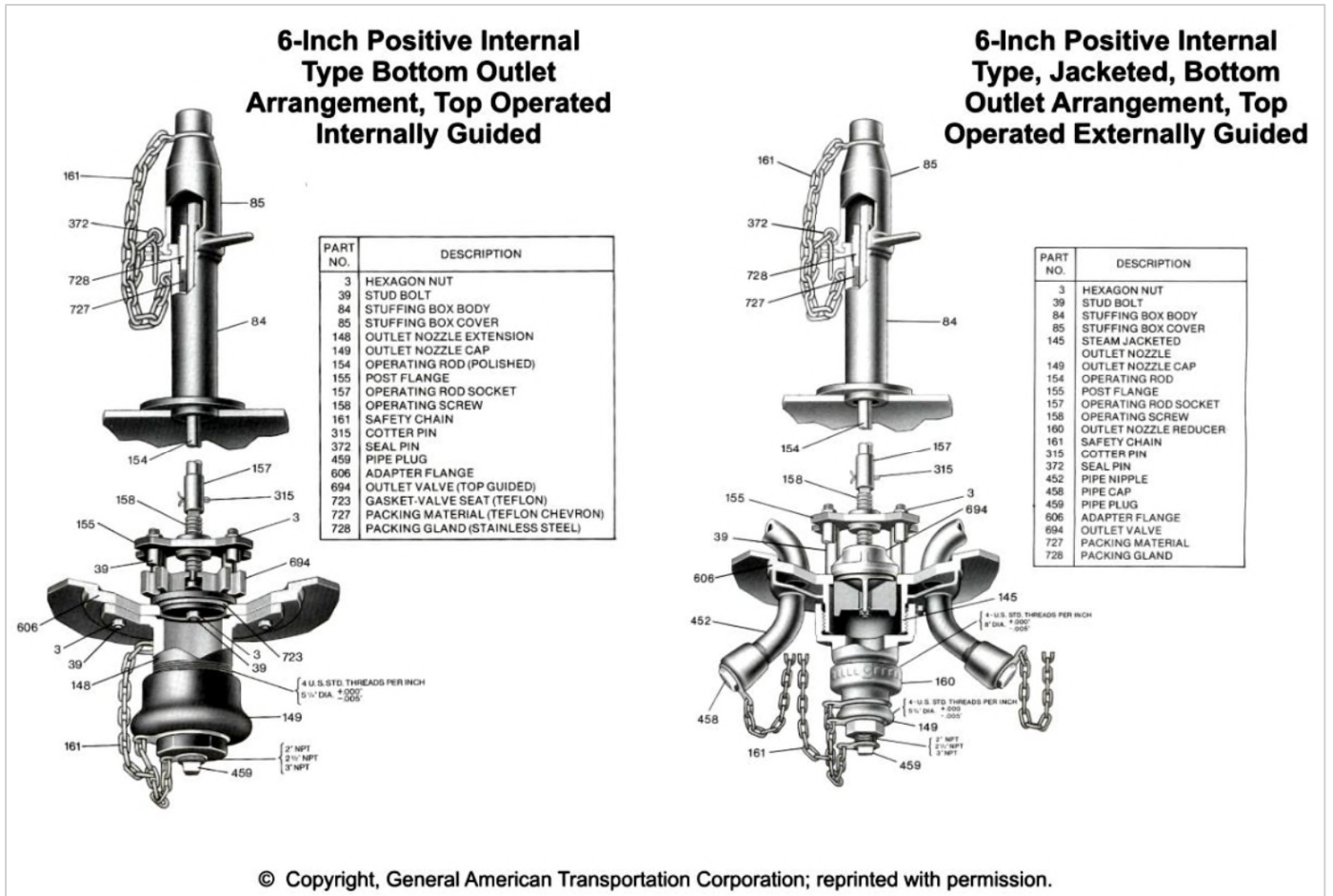

Bottom Outlet with Skid Protection (External Ball Valve)

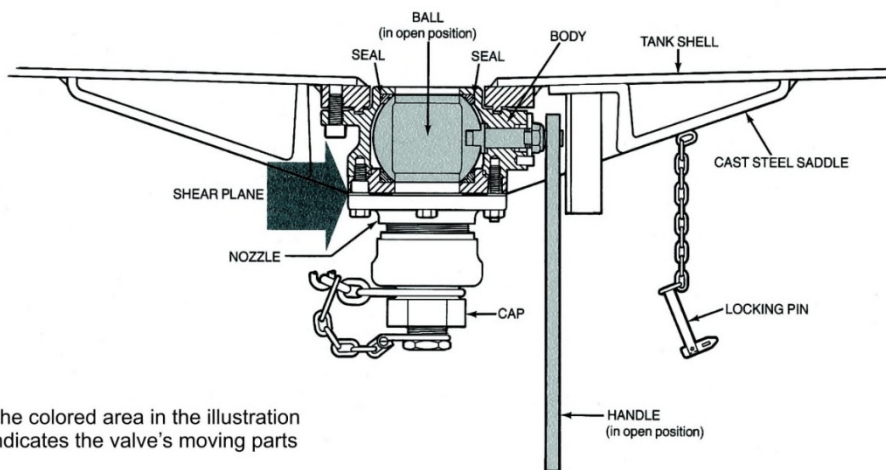

The colored area in the illustration indicates the valve's moving parts

Example of External Ball Valve



Courtesy of Neles/Jamesbury.

© Copyright, General American Transportation Corporation; reprinted with permission.

Bottom Outlet (Internal Ball Valve)

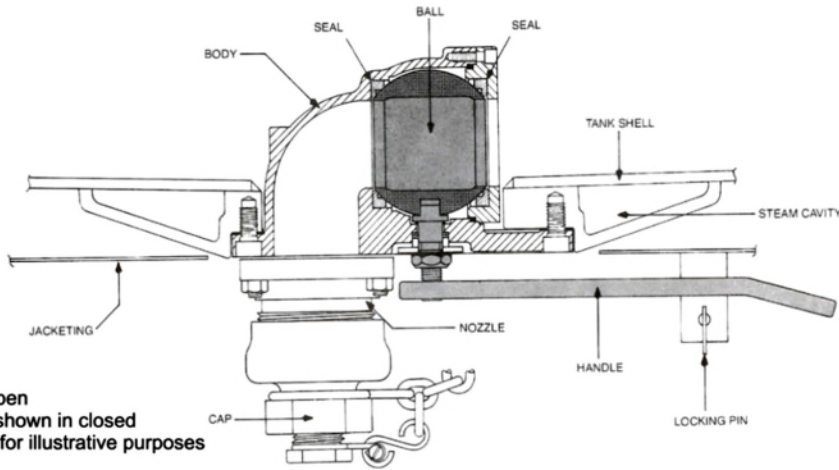

Valve Open
Handle shown in closed
position for illustrative purposes

Example of Internal Ball Valve



Courtesy of Neles/Jamesbury.

© Copyright, General American Transportation Corporation; reprinted with permission.

Jamesbury Bottom External Butterfly-Type Valve

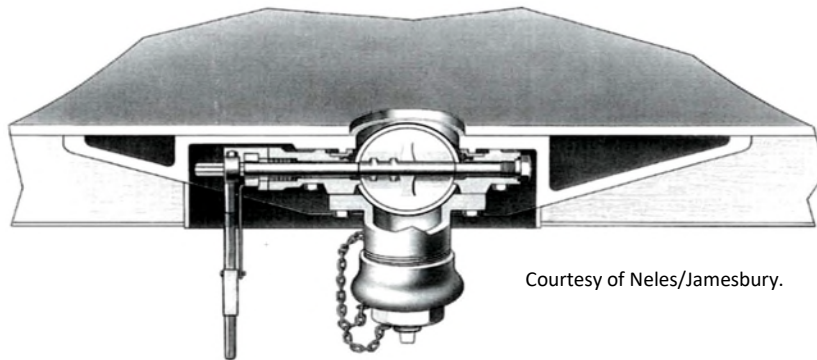

Courtesy of Neles/Jamesbury.

Typical Bottom Washout Arrangements

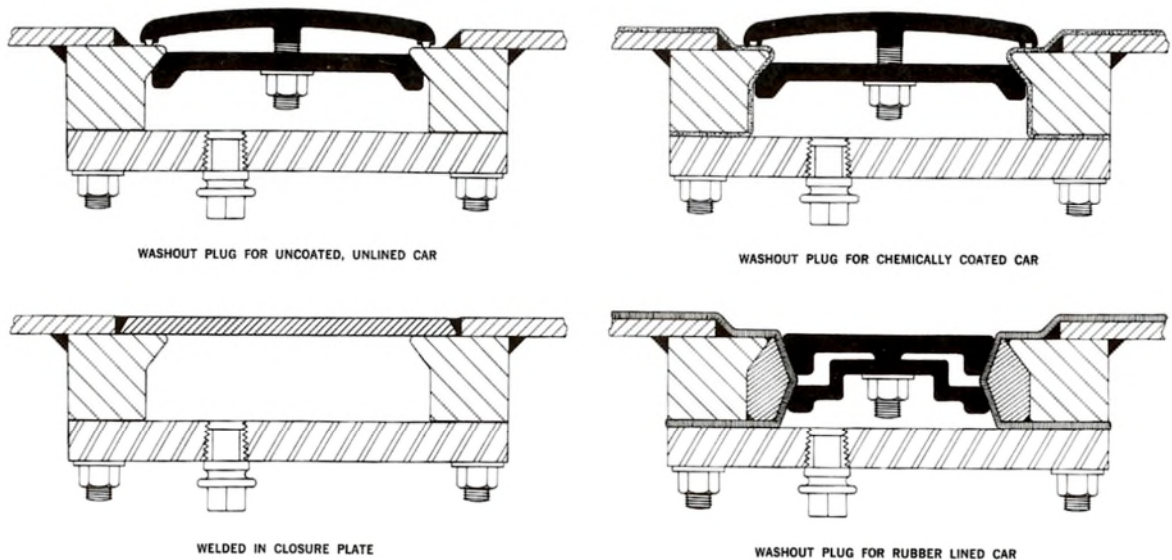

© Copyright, General American Transportation Corporation; reprinted with permission.

Heater Coil Configurations

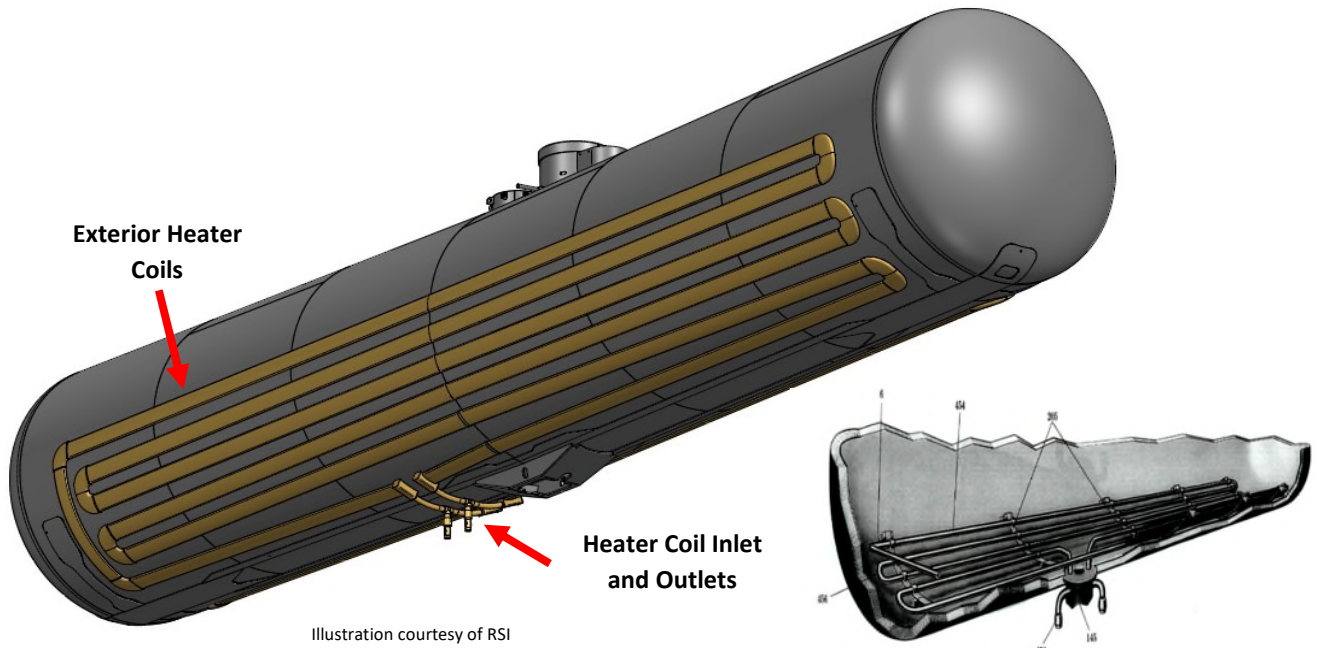

Illustration courtesy of RSI

Interior Heater Coils at Bottom Outlet

© Copyright, General American Transportation Corporations; reprinted with permission

Alternative Manway Covers



"Kelso Klincher" Single Bolt Manway

Courtesy of Kelso Technologies, Inc.



Single Bolt Manway

Courtesy of Baier Rail

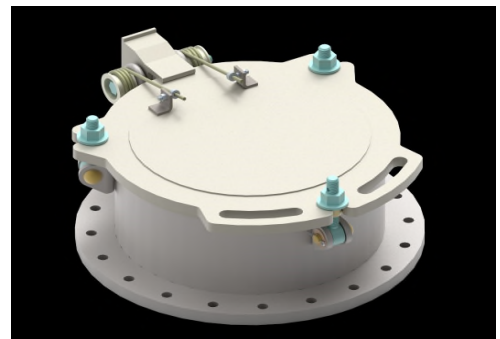

UTLX Three Bolt Manway (subject to AAR approval)

Courtesy of Union Tank Car Company.

Section 5: Pressure Tank Cars

Pressure tank cars, Classes DOT/TC-105, 109, 112, 114, and 120, are used to transport liquefied compressed gases, poison/toxic inhalation hazard (PIH/TIH) materials, reactive materials, and/or corrosive materials requiring the additional protection. There are no equivalent AAR-type pressure tank car specifications.

Minimum tank plate thickness ranges from 1/2 inch to 11/16 inch for steel tanks (depending on tank diameter and tensile strength of the plate used) and 5/8 inch for aluminum. Depending upon the specification, pressure tank cars have burst strengths from 500 psig to 1500 psig.

Class-105 insulated carbon or alloy (stainless) steel or aluminum pressure tank cars are designed for top loading and unloading. Bottom outlets and washouts are prohibited. Tank test pressures range from 100 psig to 600 psig. These cars may be equipped with tank head puncture resistance and thermal protection systems.

Class-109 insulated carbon steel or aluminum pressure tank cars are designed for top loading and unloading. Bottom washouts are authorized; however, bottom outlets are prohibited. Tank test pressures range from 100 psig to 300 psig. There are very few Class-109 tank cars in service.

Class-112 insulated or uninsulated carbon or alloy (stainless) steel pressure tank cars are designed for top loading. Bottom outlets and washouts are prohibited. These cars may be equipped with tank head puncture resistance and wrapped with thermal protection systems. Tank test pressures range from 200 psig to 500 psig.

Class-114 are insulated or uninsulated carbon or alloy (stainless) steel pressure tank cars with tank test pressures of 340 or 400 psig. These cars may be constructed of noncircular cross section, and, except for the PRD, the valves and fittings may be located somewhere other than the top of the tank.

Class-114 cars may be equipped with bottom outlets and washouts, and tank head puncture resistance and thermal protection systems. Currently, those in service are similar in appearance to Class-112 tank cars. No noncircular cross section tank cars are in service.

Class-120 tank cars are insulated steel or aluminum pressure tank cars with tank test pressures of 100 to 500 psig. Like Class-114 tank cars, they may have valves and fittings located somewhere other than the top of the tank and may be equipped with bottom outlets and washouts and tank head puncture resistance and thermal protective systems.

One tank car manufacturer has built a number of specification DOT-120J200W tank cars for the transportation of flammable liquids. These tank cars are similar in appearance to Class-117 tank cars, except the hinged and bolted manway cover is contained within a protective housing. These tank cars operate under a DOT Special Permit and Canadian Safety Permit-Rail.

Pressure tank cars are most readily identifiable by the presence of a protective housing on top of the tank (not to be confused with an expansion dome applied to obsolete nonpressure tank cars).

The loading/unloading fittings and the PRD (PRV or combination PRD) will be mounted on a manway cover or pressure plate and enclosed within the protective housing. Some tank cars in refrigerant gas or certain corrosive service may have a bottom outlet, bottom washout, and a hinged and bolted manway cover enclosed within a dome-shaped housing.

Unlike nonpressure tank cars, which may be loaded or unloaded using an open system, pressure tank cars are loaded and unloaded using a closed system, i.e., the tank is not opened to the atmosphere during the process. The manway cover or pressure plate is removed only for maintenance purposes at a tank car repair facility. Although rare, pressure tank cars may be equipped with heater coil systems.

Typically, in addition to the PRDs, a pressure tank car will have two liquid eduction lines running along the tank's longitudinal centerline with the valves facing the ends with eduction pipes reaching to the bottom of the tank and at least one vapor eduction line with the valve facing the side of the tank car with an eduction pipe extending only into the top of the tank.

The valves for liquid and vapor eduction lines are commonly called angle valves (so called because product flow through the valve is at a right angle to the flow through the eduction line). The angle valves may be either plug or quarter-turn ball style valves. Instead of angle valves, some pressure tank cars are equipped with ball valves designed for vertical flow of the product. Depending upon the tank car's service, the following additional fittings may be found mounted on the pressure plate:

- **Sample Line:** may be used to obtain a sample of the tank's lading for laboratory analysis. The device consists of an open pipe extending into the tank that may or may not go to the bottom and is closed with a control (needle) valve on the outside. To obtain a sample, a hose is connected to the control valve's port, with the other end attached to a container for the sample (usually a small compressed gas cylinder). When the control valve is opened, lading will flow into the container.

The sample line valve may also be used to attach a pressure gauge to determine the pressure within the tank. Because the sample line's pipe may not extend completely to the bottom of the tank, it cannot be relied upon to determine if there is any liquid remaining in an empty tank.

- **Gauging Device:** typically, a magnetic ball device consisting of a hollow metallic pipe, capped at the end inside the tank. A metallic ball or float equipped with ring magnets is placed around the rod. The inside of the pipe is equipped with a composite-material gauging rod, with a magnet on the lower end. As the tank is filled, the ball floats on the liquid and the magnetic force between the ball and the rod causes the rod to follow the ball, rising with the liquid level.

Magnetic Gauging Device



The gauging rod is typically graduated in one-quarter inch increments, and the liquid-level measurement can be converted to gallons of outage (vacant or vapor space in the tank) using outage tables supplied by the tank car's builder. Subtracting the outage from the tank's volumetric capacity will give the "innage" or number of gallons of product inside the tank.

In lieu of a magnetic gauging device, pressure tank cars may be equipped with electronic or "telltale" gauging devices. Telltale gauges consist of a fixed open tube that extends into the tank (but not to the bottom) with an outside control (needle) valve, similar in appearance to the control (needle) valve on a sample line. The length of the tube(s) has been predetermined to typically correspond to 1 percent and/or 2 percent, or up to 5 percent outage by volume. During loading, the control valve(s) are open, and when liquid is emitted, the designated outage has been reached.

- **Thermometer Well:** used to take the temperature of the lading. The device consists of a pipe (sealed at the bottom) filled with an antifreeze solution or oil that extends into the tank and is closed with a cap (not with a valve) on the outside. With the cap removed, a thermometer, which does not travel with the car, is lowered into the tube. The temperature of the liquid in the tube will correspond to the temperature of the lading, which is transferred to the thermometer. The external pipe and/or the thermometer well cap is equipped with telltale holes that are intended to provide a warning should there be a failure of the internal pipe. Some pressure tank cars are equipped with electronic temperature sensing devices.

- **Excess Flow Valves:** required by governmental regulations for certain commodities. An excess flow valve (not to be confused with a check valve that only allows flow in one direction) is a device that closes automatically against the outward flow of the contents of a tank in case the external closure valve is broken off or removed during transit.

Excess flow valves may be equipped with a bypass feature that allows for pressure equalization. Excess flow valves are neither designed nor intended to stop the flow of a tank car's contents in the event of a failure of a loading/unloading system's piping or hoses.

For commodities that have a primary or subsidiary hazard of Division 2.1 (flammable gas) material hazard, the interior (eduction) pipes for the loading and unloading valves and sample devices must be equipped with excess flow valves. Tanks transporting PIH/TIH materials must have excess flow valves under the liquid valves. (See "Alternative Fittings Package" for exceptions, page 52.)

Although not required by regulation, pressure tank cars transporting other commodities may be equipped with excess flow valves; e.g., a tank car may be in dual service, wherein it transports LPG (Division 2.1) requiring excess flow valves during part of the year and anhydrous ammonia (Division 2.2), which does not require excess flow valves, during other times of the year.

Fittings for the Most Common Commodities Shipped in Pressure Tank Cars

Liquefied Compressed Gases (e.g., propane, butane, and propylene), vinyl chloride, butadiene, and anhydrous ammonia:

- Two liquid eduction lines along the centerline of the tank with the eduction valves pointing towards the ends of the car each with an eduction pipe reaching to the bottom of the tank.
- One vapor eduction line with the eduction valves pointing to the side of the car with an eduction pipe extending only into the top of the tank.
- Pressure relief valve.
- Thermometer well.
- Sample line.
- Magnetic gauging device.

Chlorine and Sulfur Dioxide:

- Two liquid eduction lines along the centerline of the tank with the eduction valves pointing towards the ends of the car.
- Two vapor eduction lines with the eduction valves pointing to the sides of the car. A limited number of tank cars equipped with a dual valve fittings package may be found with one instead of two vapor eduction lines (see pages 58 and 59 for an examples)
- Combination pressure relief device (breaking pin or rupture disc beneath a pressure relief valve).
- No gauging device, sample line, or thermometer well.

Carbon Dioxide

- One liquid eduction line with an eduction valve and one vapor eduction line with an eduction valve along the centerline of the tank with the valves pointing towards opposite ends of the car. Typically, these eduction valves will be identified on a plate inside the protective housing or by the letters L (for liquid) and V (for vapor) applied to the interior wall of the protective housing.
- Two pressure regulating valves.
- Pressure relief valve.
- Safety vent/rupture disc device.
- Two or more fixed-length, telltale outage gauges.
- Thermometer well.

DOT/TC-112J340W Tank Car (Liquefied Compressed Gases)



Characteristics:

- 11/16-inch normalized AAR TC128, Grade B, steel tank
- Jacketed thermal protection required
- Insulation optional
- 1/2-inch thick full-height head shields built into jacket
- Top fitting protection (protective housing) (See page 76 for fittings inside the protective housing)
- Reclosing pressure relief valve
- Bottom outlet prohibited
- Bottom washout prohibited

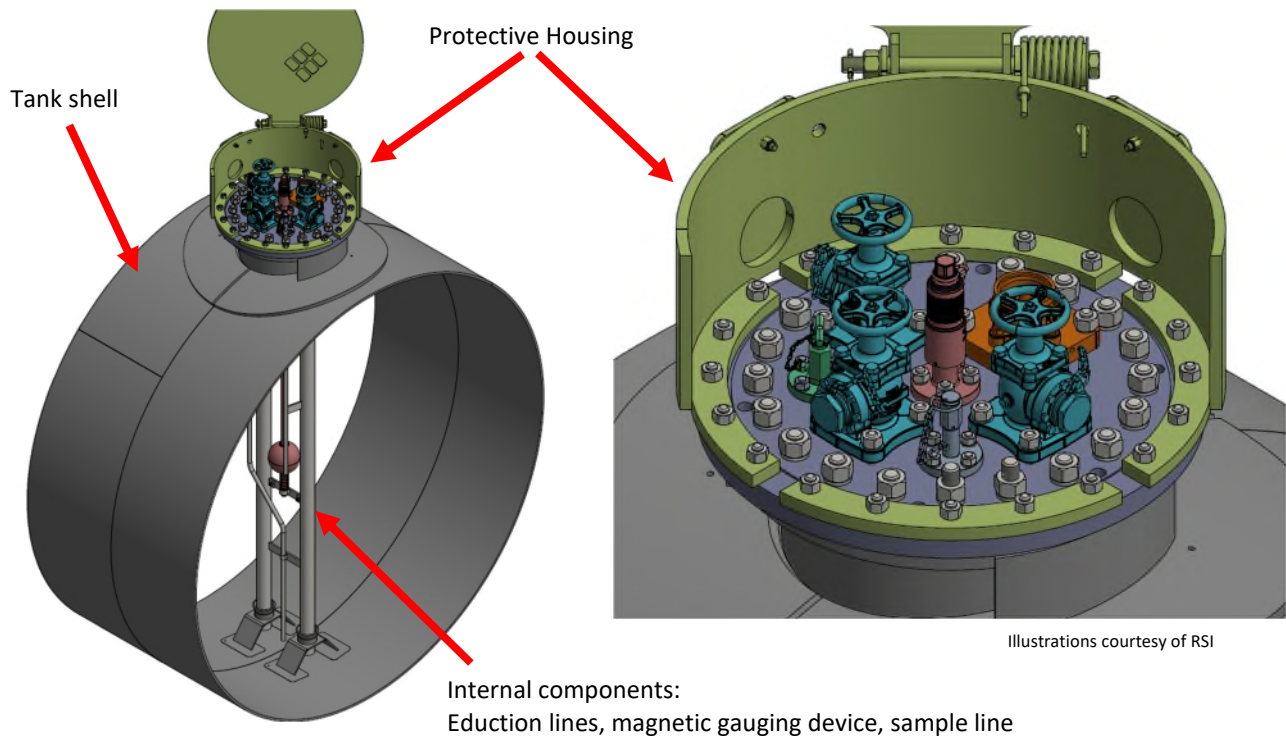

Illustrations courtesy of RSI

Fittings Arrangement - DOT/TC-112J340W Tank Cars

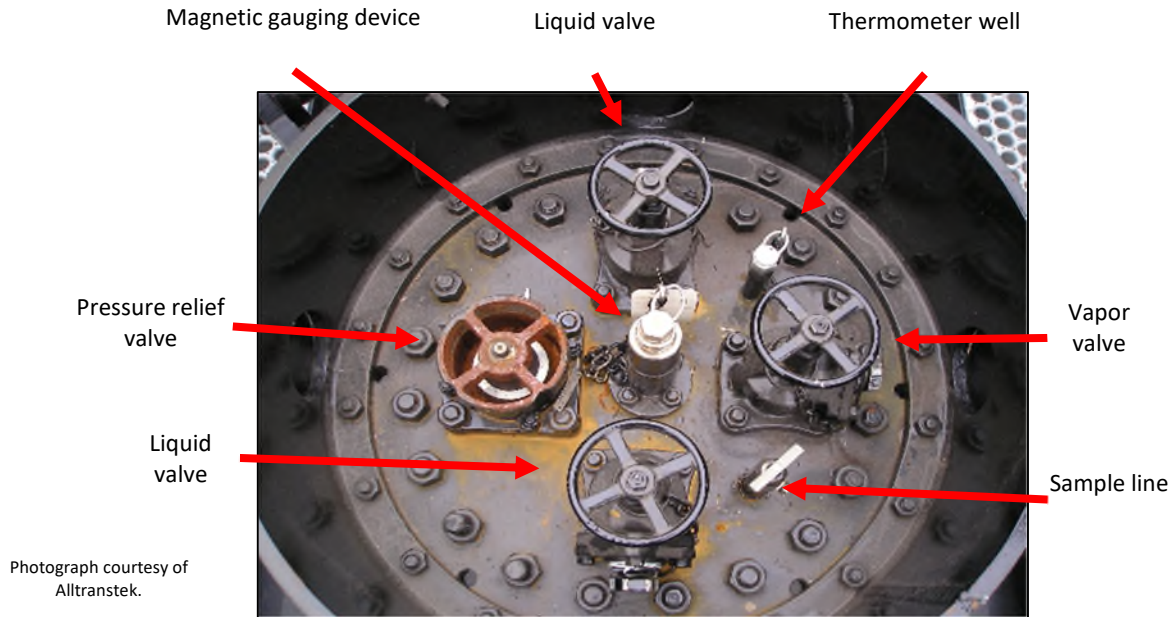

DOT/TC-112S500l Tank Car (Anhydrous Hydrogen Fluoride)



Characteristics:

- Minimum 11/16-inch normalized TC128 Grade B steel tank
- 1/2-inch thick full-height head shields
- Top fittings protection (protective housing)
- Combination pressure relief device
- Bottom outlet prohibited
- Bottom washout prohibited

Note: The letter "S" in the specification indicates the tank car is equipped with full-height head-shields.



Photographs Courtesy of Barry Lindley

DOT/TC-105J500W Tank Car (Chlorine)



Characteristics:

- 15/16-inch AAR TC128 Grade A or B normalized carbon steel or ASTM A 516 Grade 70 normalized carbon steel tank
- Jacketed thermal protection and insulation
- 1/2-inch thick full- or half-height head shields built into jacket
- Top fittings protection (protective housing)

- Two liquid valves pointing toward the ends of the tank each with an excess flow valve and eduction pipe reaching into the bottom of the tank
- Two vapor valves pointing to the side of the tank with an eduction pipe extending only into the top of the tank
- Combination pressure relief device
- Bottom outlet prohibited
- Bottom washout prohibited

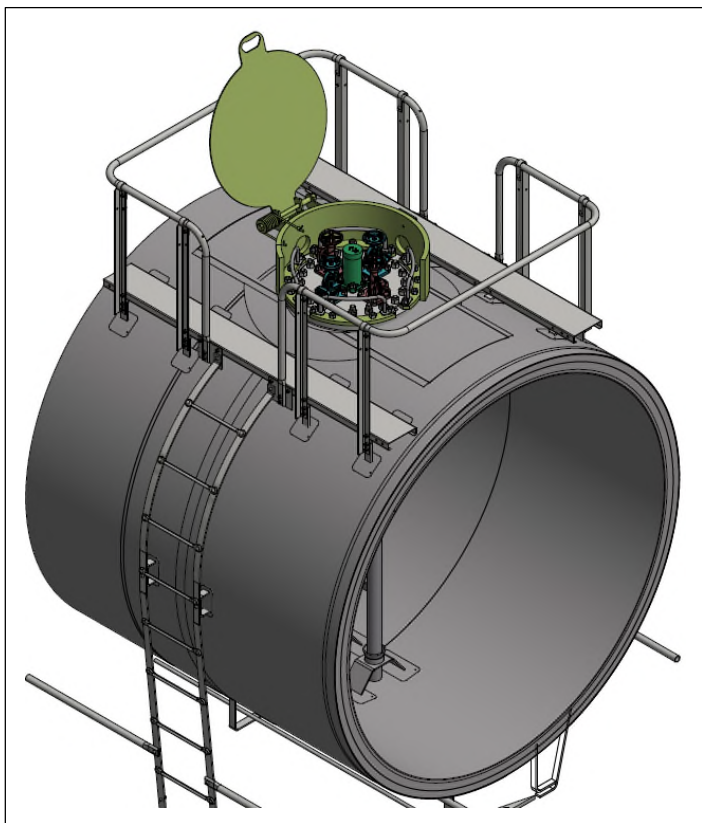

Illustrations courtesy of RSI

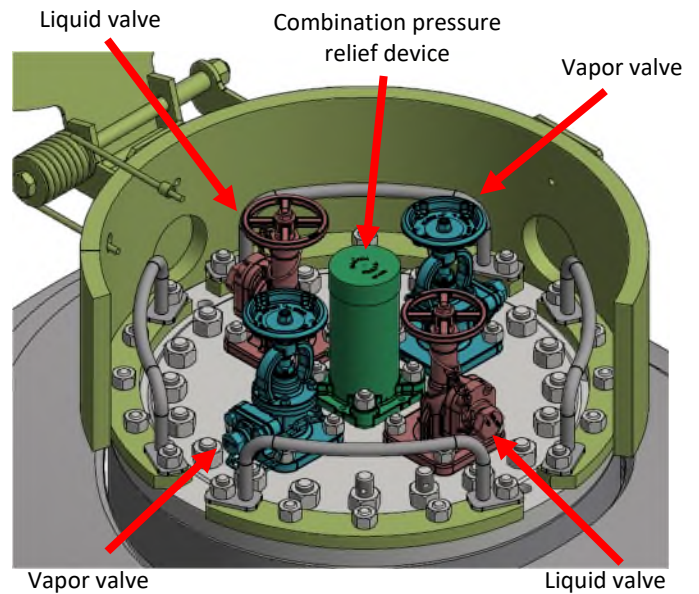

DOT/TC-105J500W Tank Car (Carbon Dioxide)



Characteristics:

- 0.787-inch AAR TC128 Grade A or B normalized carbon steel or ASTM A 516 Grade 70 carbon steel tank
- 1/2-inch thick full- or half-height head shields built into jacket
- Jacketed thermal protection and insulation required
- Continuous underframe
- Top fitting protection (protective housing)
- Bottom outlet prohibited



Note: Regulations require that the final discharge of the regulating valves, PRV, and rupture disc must be piped to the outside of the protective housing and identified by stenciling “REGULATING VALVES VENTING NORMAL”, “RELIEF VALVE”, “REGULATING VALVES”, and/or “RUPTURE DISC”, as appropriate, over or under the discharge pipes from the respective devices. Under no circumstances should these discharge pipes be plugged or otherwise blocked.

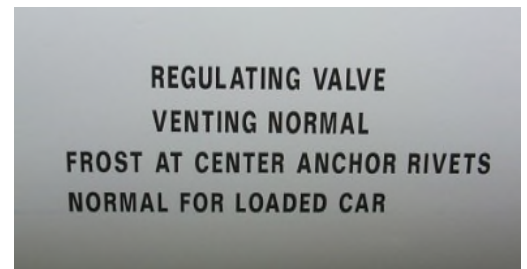

Fittings Arrangement - Carbon Dioxide Tank Cars

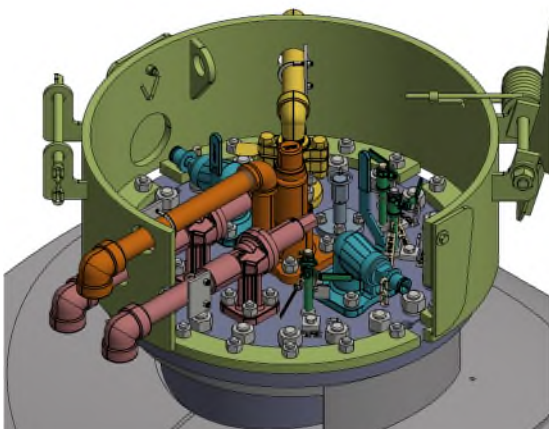

Illustrations courtesy of RSI

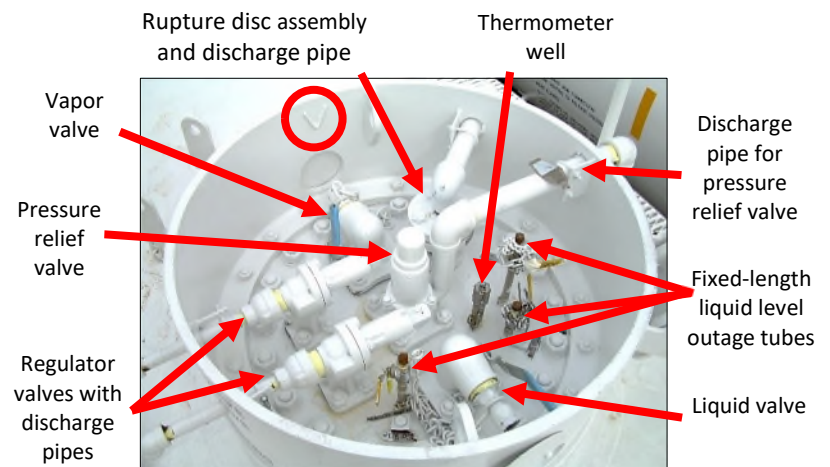

“V” on housing indicates vapor line “L” on housing indicates liquid line

DOT/TC-120J200W Tank Car (Flammable Liquids)



Characteristics:

- 9/16-inch normalized TC128 Grade B carbon steel tank
- Jacketed thermal protection
- Jacketed insulation optional
- 1/2-inch thick full-height head shields built into jacket
- Two protective housings – one for manway and the other for top fittings (liquid valve, air valve, and reclosing pressure relief valve, and vacuum relief valve)
- Bottom outlet optional
- Bottom washout optional

Top Fittings Protection Requirements for Tank Cars Transporting Materials Poisonous (Toxic) by Inhalation (PIH/TIH Materials)

As mentioned in Section 1: Tank Car Classification and Specifications, the U. S. DOT issued new rules in January 2009 requiring enhanced safety measures for tank cars transporting PIH/TIH materials. (See Note on page 13 for additional information.)

A tank car built after March 16, 2009, for the transportation of a PIH/TIH material, must have the service equipment enclosed within a protective housing and cover.

In addition, it must be equipped with a top fittings protection system and nozzle capable of sustaining, without failure, a rollover accident at a speed of 9 miles per hour, in which the rolling protective housing strikes a stationary surface assumed to be flat, level, and rigid.

Failure is deemed to occur when the deformed protective housing contacts any of the service equipment, or when the tank retention capability is compromised.

After December 31, 2020, tank cars manufactured with non-normalized steel for head or shell construction may not be used for the transportation of PIH/TIH materials.

Alternative Fittings Package and Tank Car Designs for PIH/TIH Materials

Over the years, various industry groups have researched alternative fittings and tank car designs for PIH/TIH materials with the objective of identifying features that provide an equivalent or improved level of safety. Some of this research resulted in alternative designs that may be seen in service.

Alternative Fittings Package

As an alternative design for top fittings rollover protection on DOT/TC specification tank cars transporting PIH/TIH commodities, a limited number of tank cars are equipped with a “dual valve fittings package” that prevents the release of product from any top fitting in the case of an accident where any fitting would be sheared off or otherwise damaged.

The primary differences with the alternate dual valve fittings package compared to the traditional chlorine fittings arrangement include:

- Tank cars are equipped with one vapor valve instead of two. In this case, the PRD is located where the second vapor valve would have been located.
- Each liquid and vapor valve is equipped with a spring-loaded check valve underneath the pressure plate instead of an excess flow valve under each liquid valve. When closed, the spring-loaded check valve provides the positive seal during transport as described above.
- The combination PRD is equipped with a rupture disc embedded in the pressure plate, which provides the positive seal described above, instead of a breaking pin or rupture disc located underneath the pressure plate.

See the illustrations on page 59 for examples of these devices.

Alternative Tank Car Design

This design involves a concept (referred to as a “tank-within-a-tank”) wherein the “outer tank” is only anchored to the “inner” (commodity) tank at the nozzle, and the bottom of the inner tank rests on cradles within the outer tank. DOT SP-15036 and Transport Canada SR-10521 has been authorized to transport chlorine in a tank car design alternative to the DOT/TC specifications.

DOT/TC-112H500W Tank Car (PIH/TIH Materials)



Characteristics:

- Minimum 11/16-inch normalized TC128 Grade B steel tank
- Must be equipped with a top fitting protection system and nozzle capable of sustaining, without failure, a rollover accident at a speed of 9 miles per hour
- 1/2 inch thick full-height, external head shield (may be built into jacket).
- Tank jacket and support structure system is capable of withstanding a 6 mile per hour coupling without jacket shift such that results in damage to the nozzle.
- Reclosing pressure relief valve
- Bottom outlet prohibited
- Bottom washout prohibited

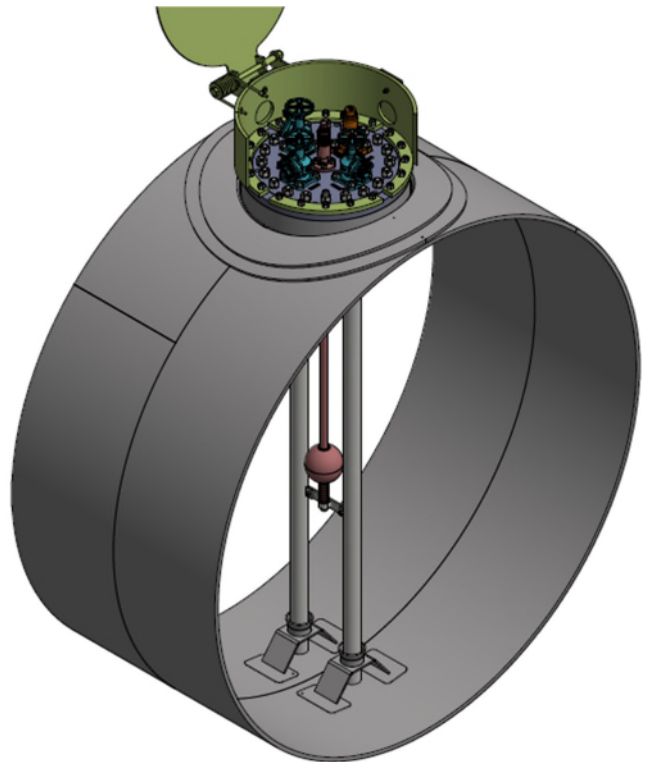
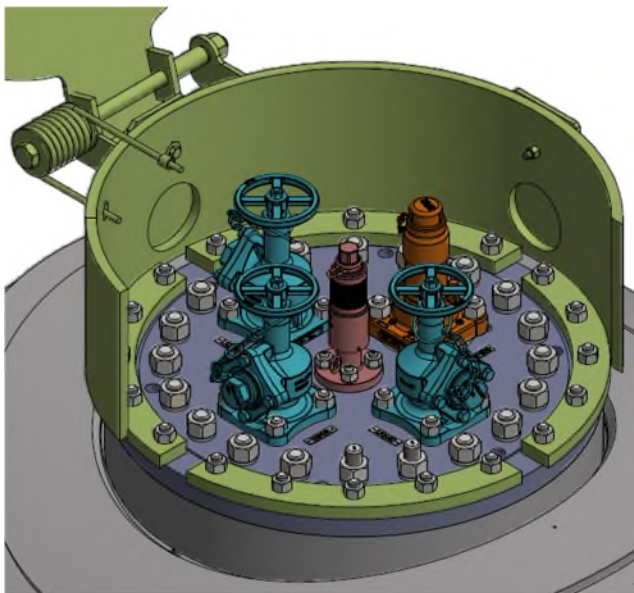
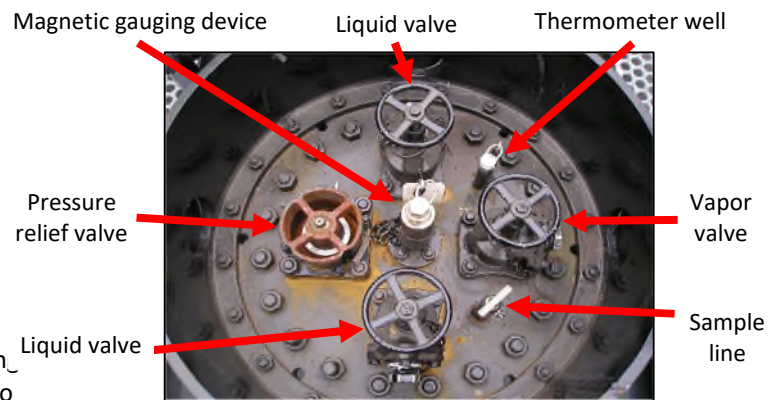

Illustrations courtesy of RSI

DOT/TC-105H600W Tank Car (PIH/TIH Materials)



Characteristics:

- 15/16-inch AAR TC128 Grade A or B normalized carbon steel or ASTM A 516 Grade 70 normalized carbon steel tank
- Must be equipped with a top fitting protection system and nozzle capable of sustaining, without failure, a rollover accident at a speed of 9 miles per hour
- 1/2 inch thick full-height, external head shield (may be built into jacket).
- Jacketed thermal protection and insulation with tank jacket and support structure system capable of withstanding a 6 mile per hour coupling without jacket shift such that results in damage to the nozzle.
- Reclosing pressure relief valve
- Bottom outlet prohibited and bottom washout prohibited

DOT/TC-105J (DOT-SP 15036/TC-SR 10521) Tank Car (Chlorine)



Characteristics:

- Inner tank within an outer tank design - thicker outer tank
- Thermal protection and insulation
- 1/2-inch thick full-height head shields built into outer tank
- Top fittings protection (protective housing)
- Dual valve fittings package with two liquid lines and one vapor line (equipped with spring-loaded check valves)
- Combination pressure relief device with reclosing pressure relief valve and nonreclosing rupture disc assembly.

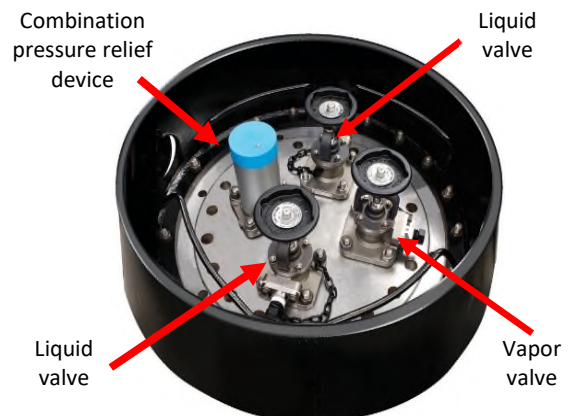

Tank car photo courtesy of UTLX Manufacturing.

Fittings illustration courtesy of Midland Manufacturing Company.

Cutaway View of Dual Valve Fittings for Chlorine Tank Cars

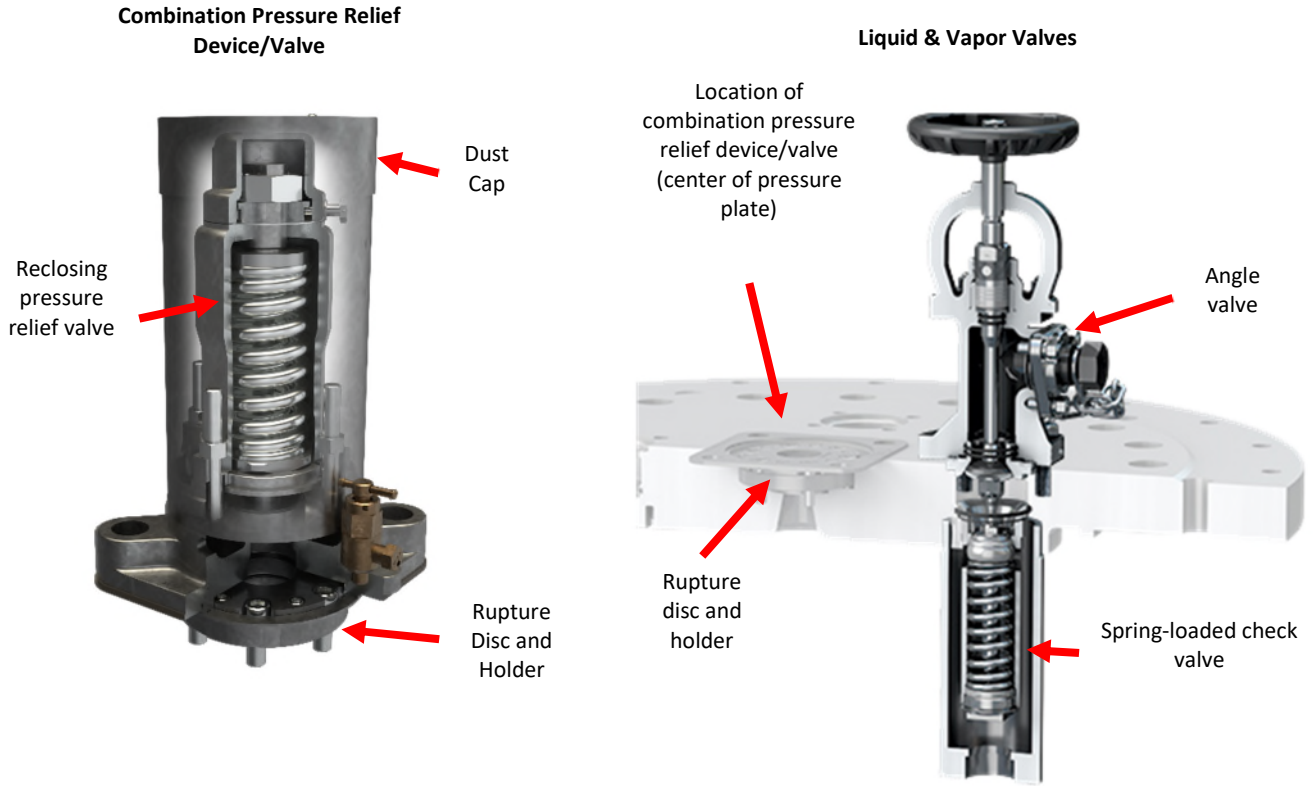

Source: Midland Manufacturing

Section 6: Cryogenic Liquid Tank Cars

Cryogenic liquid tank cars, Class DOT/TC-113 and Class AAR-204, are vacuum-insulated tank cars having an inner tank within an outer tank, not a jacket.

The inner tank is constructed of alloy (stainless) steel. The outer tank is constructed of carbon steel, 7/16 inch to 9/16 inch thick with 1/2 inch to 9/16 inch thick heads. Cryogenic tank cars are designed to transport refrigerated liquefied gases having a boiling point colder than minus 130°F at atmospheric pressure including liquid hydrogen, oxygen, ethylene, nitrogen, methane/liquefied natural gas (LNG), and argon.

The annular space between the inner and outer tanks has a vacuum drawn and is equipped with an insulation system using an alternating wrap of multiple layers of aluminum foil and paper or granular perlite. These tank cars are frequently referred to as Thermos® bottle tank cars.

The insulation system (designed for the commodity being transported and meeting specified performance standards) and vacuum controls the rate of heat input for normal transportation time periods.

Note: DOT regulations require the shipper to notify the Federal Railroad Administration whenever a tank car containing any flammable cryogenic liquid is not received by the consignee within 20 days from date of shipment. Typically, the insulation system will keep the commodity pressure from activating the PRDs for at least double this 20-day period.

Specification DOT/TC-113A60W tank cars have a design service temperature of minus 423°F, a minimum burst pressure of 240 psig, and a tank test pressure of 60 psig.

Specification DOT/TC-113C120W tank cars have a design service temperature of minus 260°F, a minimum burst pressure of 300 psig, and a tank test pressure of 120 psig.

Note: On June 19, 2020, the Department of Transportation's Pipeline and Hazardous Materials Administration (PHMSA) issued a "Final Rule", Docket No. PHMSA-2018-0025 (HM-264) which authorizes the transportation of liquefied natural gas (LNG) in a new tank car specification: DOT-113C120W9.

The DOT-113C120W9 tank car is required to have the outer tank with a minimum thickness of 9/16-inch (compared to 7/16-inch for other Class DOT 113C tank cars). In addition, the outer tank must be constructed of TC-128, Grade B (TC-128B) normalized steel to obtain improved crashworthiness. The inner tank design and safety features to vent the contents in the event of an unsafe pressure increase remain identical to other DOT 113C120W tank cars.

Specification AAR-204W tank cars must meet the specification requirements for Class-113 tank cars, with some exceptions. The minimum required burst strength is 240 psig, with a 60 psig tank test pressure. Specification AAR-204W tank cars are not authorized for Division 2.1 (flammable gas) materials.

Cryogenic liquid tank cars are required to have two liquid-level gauges. One gauge measures the liquid level in the inner tank (this gauge may be a portable gauge that does not move with the car) and the other gauge, a fixedlength dip tube set, indicates the maximum allowable liquid level for the allowable filling density. In addition, the car must be equipped with a vapor-phase pressure gauge to indicate the pressure within the inner tank.

The cars must be equipped with various PRDs for the protection of the tank assembly and piping system. The discharge of the PRD must be directed away from operating personnel, the car structure, trucks, and safety appliances; e.g., steps, handholds/grab irons, and handrails.

The inner tank must be equipped with at least one PRV and at least one safety vent (rupture disc device), which may be replaced by an alternate PRV. The car may also be equipped with a pressure control device (regulator valve) and mixing device to control the routine release of vaporized lading during transportation. Tank cars in

liquid hydrogen service must be equipped with a device that will instantly ignite any hydrogen that is discharged through the PRDs. The outer jacket/tank must be equipped with a system to prevent buildup of pressure within the annular space.

The loading/unloading valves and other fittings are required to be enclosed within a protective housing (not to be confused with protective housings on pressure tank cars), which appears to be a box or cabinet. The protective housing(s) is located on both sides, at one end or, in rare cases, on the top of the car. The housing(s) must be adequate to protect the fittings from direct solar radiation, mud, sand, adverse environmental exposure, and mechanical damage incident to normal operation.

The protective housings for the fittings must be equipped with precautionary instructions for the safe operation of the equipment during storage and transfer operations, and must include a diagram of the tank and piping system with the various gauges, control valves, and PRDs clearly identified, and their location indicated. In addition, all valves and gauges must be clearly identified with corrosion-resistant nameplates.

In addition to other stenciling, cryogenic liquid tank cars must be stenciled “DO NOT HUMP OR CUT OFF WHILE IN MOTION” and “VACUUM JACKETED” on both sides in lettering at least 1 1/2 inches high.

Typical Class DOT/TC-113 Tank Car (Cryogenic Liquids)



Characteristics:

- Vacuum-insulated tank with an alloy (stainless) steel inner tank at least 3/16-inch thick, supported concentric within a carbon steel outer tank at least 7/16-inch thick (for DOT-113C120-W9 tank cars, the minimum thickness is 9/16-inch)
- Piping systems for vapor venting and transfer of lading, and with pressure relief devices (PRV and rupture disc), controls, gauges and valves in a fittings compartment (box or cabinet) located on both either both sides, at one end, or on top the car.
- Vacuum jacketed – perlite or “super insulation”

Typical Fittings Arrangement - Class DOT/TC-113 Tank Cars

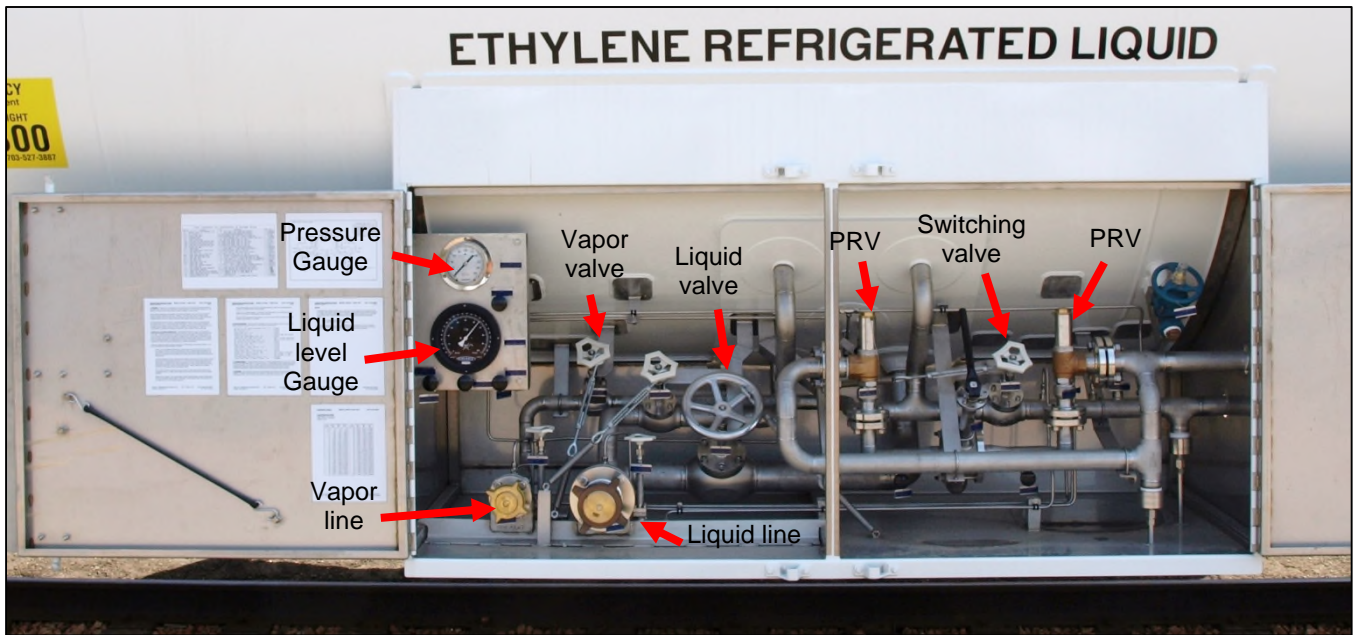

Photograph Courtesy of Chart Industries.

Fittings Diagram - Class DOT/TC-113 Tank Car

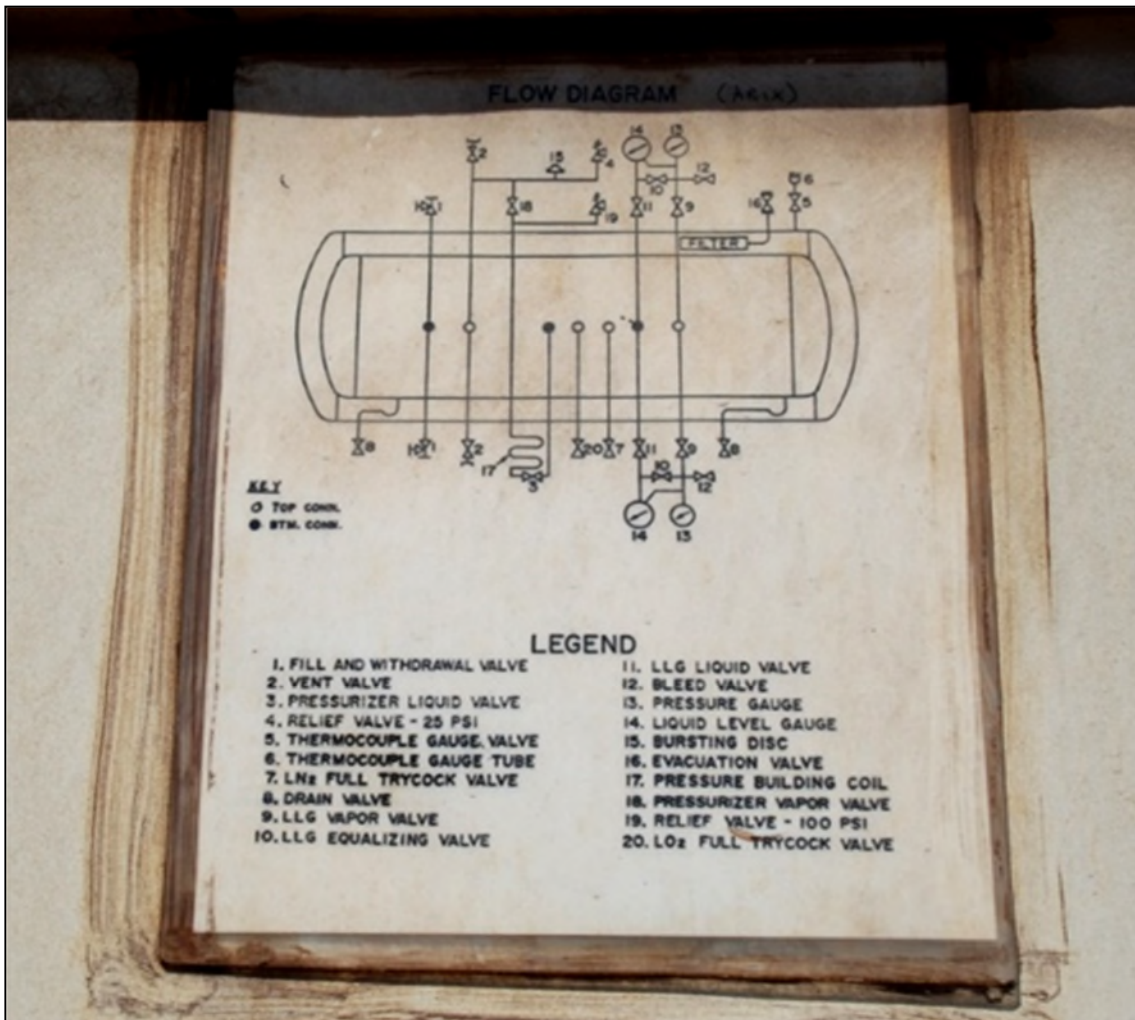

Photograph courtesy of Tony Bacino.

Section 7: Guidelines for Initial Emergency Response

Accidents involving tank cars must be evaluated and approached with great care due to the possible presence of hazardous materials/dangerous goods and potential damage to containers. Absence of visible hazard warning labels, markings, or placards is not a guarantee that commodities involved are harmless.

A thorough analysis, assessing the hazards and consequences or risks, and developing a risk-based, survival-oriented response plan are critical for managing an accident involving tank cars. This analysis and planning must be based on facts, science, and circumstances unique to the accident.

- Facts include the commodity, the container and its damage, and the exposures (people, property, environmental issues, and critical systems).
- Science includes physical and chemical hazards of the commodity.
- Circumstances include behavior of the container and its contents, proximity of the exposures, and the ability to influence the outcome based on resources, training, and skills available.

It is possible that an accident involving hazardous materials/dangerous goods will present such a high degree of hazard that the only safe course of action is to evacuate ALL personnel from the area and allow the accident to run its own course without intervention.

Initial Notifications

Upon arrival at a rail transportation accident, your first step is to avoid endangering yourself and call for help.

- Immediately notify the local emergency response agency.
- After notifying the local emergency response agency, contact the operating railroad directly for emergency response and technical assistance at its Emergency Response Telephone Number.
- After receiving the shipping papers/shipping documents (paper or electronic), call the emergency response telephone number(s) listed for the particular car involved shown.

Provide as much of the following information as you can when calling for assistance:

- Your name, location, and telephone number.
- Location of accident.
- Type containers or vehicles involved.
- Wind direction and approximate speed.
- Presence of injured people.

Numbers for Major Carriers

- **BNSF Railway:** 800-832-5452
- **Canadian National Railway:** 800-465-9239
- **Canadian Pacific Railway:** 800-716-9132
- **Conrail:** 856-231-6400
- **CSX Transportation:** 800-232-0144
- **Kansas City Southern Railway:** 877-527-9464
- **Norfolk Southern Railway:** 800-453-2530
- **Union Pacific Railroad:** 888-877-7267
- **Railway Association of Canada (RAC):** 1-647-206-2896.
RAC personnel are available for emergency response and technical assistance at railroad incidents involving dangerous goods in Canada.

- Presence of smoke, fire, or fumes.
- Presence of markings, labels, or placards on containers or vehicles.
- Carrier name.
- Other pertinent information.

Initial Actions

After the initial notifications are made, isolate the hazard area and deny entry. Make sure your vehicle is far enough away from the scene so that the hot exhaust system scene does not provide a possible ignition source. Turn off vehicle's ignition. Do not smoke, use flares, fusees, or open flames near the scene. Remain a safe distance upwind from the site. Resist the urge to rush into an accident site and rescue injured personnel until after the commodities are identified and the nature and severity of the hazard is identified.

AskRail® App

The [AskRail® app](#) is a collaborative effort among all North American Class I railroads, the Association of American Railroads, and Railinc Corp. The app is a safety tool that provides first responders immediate access to accurate, timely data about the commodity a railcar is carrying. AskRail® is a backup resource if information from a train crew or train consist is not available. For security reasons, only qualified emergency responders can download and use the restricted features in the AskRail® app. In addition, railroads can offer the app to known emergency responders along their routes.

Use binoculars to survey the accident site and surrounding area. Make notes and sketches, as necessary. Pay particular attention to:

- Indications of the presence of hazardous materials/dangerous goods (container shape, markings, labels, and placards, shipping paper entries, and the AskRail® app).
- Commodities involved using markings, labels, and placards, shipping papers/shipping documents, and the AskRail® app.
- Containers or vehicles involved, including reporting marks (letters) and number, visible container or vehicle damage, and physical form of the commodity released from the container or vehicle (solid, liquid, vapor, gas).
- Exposures (people, property, environment, and critical systems) and their location and proximity to surrounding hazards.
- Accessibility to site and possible escape routes.
- Weather conditions.
- Topographical features of the site and surrounding areas, especially bodies of water.

Report the above information directly to other response organizations as soon as possible. When identifying chemical commodities involved, copy names and other information precisely. Even minor spelling errors can have serious consequences in determining the properties of commodities involved.

Identifying Commodities Involved

Before entering the accident site, identification of the commodities and containers or vehicles involved is essential. The shipping papers/shipping documents are the best source for this information.

In train operations, the required shipping description entries are typically contained in a train consist, train list, or wheel report, and are in the possession of a member of the train crew. These shipping papers/shipping documents will identify whether the commodity is hazardous, and where the rail car is located in the train. This information may also be available by contacting the railroad by phone.

Through authorization under Special Permits, some rail carriers operate trains using electronic shipping documents instead of paper shipping documents. A member of the train crew can provide responders with shipping documents through various electronic means such as email, Air Drop, or by provide responders with the physical device.

In a rail yard or terminal operations, shipping papers/shipping documents are available from the switch crew working the cars or at the yard office.

If shipping papers/shipping documents are not available from the train crew or switch crew, contact the operating railroad through their emergency response number. The AskRail® app, CHEMTREC, and CANUTEC are backup resources for information.

In the absence of shipping papers/shipping documents and using binoculars from a safe distance upwind, try to locate any 4-digit identification numbers on the placards (or orange panels) applied to the containers or vehicles and/or labels on nonbulk packages. Some containers or vehicles have the name of the commodity stenciled on the sides of the container or vehicle. This may help determine the presence of hazardous materials/dangerous goods.

If shipping papers/shipping documents, placards, markings, or labels are destroyed, the reporting mark and number on the railcar or intermodal container can often be used to help identify the commodities present. Rail car reporting marks are a series of letters (those ending with an X are privately owned - not owned by a railroad) followed by a series of numbers, e.g., BOEX 123456. Intermodal containers use a similar numbering pattern. Trailers have numbers but may not have reporting marks. With this information, the carrier will be able to determine the commodity involved.

Attempting to retrieve shipping papers/shipping documents or obtain the commodity name from the containers or vehicles should only be tried if it can be done without undue risk to personnel. Unidentified spilled commodities should be approached with caution. Use the appropriate level of personal protective equipment for the hazards.

Tank Car Damage Assessment

Assessment of tank car damage is not a casual matter and requires the presence of trained specialists. The guidelines presented in this section are intended only to allow those first on the scene to make an initial appraisal of railroad tank car tank damage for purposes of determining what actions should be taken until trained specialists are available.

Note: *These guidelines may not be appropriate for assessment of damage to other types of transportation and storage tanks, such as tank trucks, tank trailers, portable tanks, and stationary tanks.*

Additional information regarding tank car damage assessment may be found in a document entitled “Assessment Best Practices: Tank Car Tank Damage” at www.aar.org/BOE under Reference Materials.

Safety Issues

Tank car damage assessment is inherently dangerous, so:

- Limit access to danger area until a site safety plan is in place based on the facts, science, and circumstances unique to the situation
- Do not attempt damage assessment while there is:
 - Flame impingement on a tank, particularly on the vapor space of the tank
 - Pool fire affecting any portion of the tank
 - Any evidence that a pressure relief valve (PRV) is operating periodically, indicating that internal pressure is continuing to build
 - Bulging of a tank that has not yet ruptured and has continuing exposure to a heat source
 - Unsafe conditions that limit access to the tank

Inspecting Damaged Tank Car Tanks

Tank cars and other bulk containers involved in accidents may suffer severe damage without loss of lading. This damage may look impressive, even awesome, yet the car or container may still have sufficient strength to permit it to be carefully removed from the accident site for later transfer or unloading of the commodity.

The most serious damage that can occur to tanks and other containers transporting compressed gases is caused by mechanical damage (bending, denting, scoring, or gouging) without resultant leaks. Time, pressure, and handling can result in delayed rupture of the tank.

Each visible crack, dent, score, or gouge must be examined. As adjacent cars or surrounding materials are removed or as the tank car itself is moved, newly exposed surfaces must be examined as well.

All liquefied gases (except cryogenic liquids) are shipped in tank cars with jacketed thermal protection. Tank damage refers to damage to the tank containing the commodity, not to the jacket surrounding that tank. The presence of a jacket may be determined by looking to see if ripped or torn metal reveals insulating materials. The jacket may also be noted by the flashing over the body bolster, flat spots on the sides or ends of tanks, and lap welds. Removing a jacket to access the tank for damage assessment should only be done under the supervision of railroad personnel.

Dents in combination with scores, gouges, or cracks and dents which cross a weld seam are the most dangerous and the tighter or smaller the radius or curve of the dent, the more dangerous it is. Dents that run lengthwise on the cylindrical section of the tank are usually considered to be more dangerous than large dents in the head. But even large head dents are dangerous, if they appear in conjunction with a gouge, score, or crack. Small head dents not exceeding 12 inches in diameter, especially in tightly bent edges, should be considered marginal and may justify unloading in place, usually by transferring the commodity to another tank car or other container on site rather than attempting to move or rerail the tank car.

Note: *The heat affected zone (HAZ) is the area of a welded joint, adjacent to the weld material, where the base metal which was not melted but has had its microstructure and properties altered by heat of welding and subsequent re-cooling. This zone is less ductile than either the weld or the plate base material/parent metal due to the effect of the heat of welding.*

Cracks in the base metal of a tank, especially if in combination with a dent or gouge, justify unloading the tank before it is moved, except as may be necessary to get the valves upright or accessible.

Scores or gouges are especially dangerous if they run lengthwise over a distance of 7 feet, cross into the heat affected zone of a welded joint on the tank, and/or are greater than 1/16 inch in depth.

To repeat, assessment of tank damage is a skill that requires training and experience. Factors include evaluation of damage to the tank itself, outside air temperature, commodity involved, its vapor pressure, and the internal pressure. In the event of a spill and/or fire, refer to the EVACUATION section of the applicable Guide(s) (orange page) contained in the *2020 Emergency Response Guidebook*.

Flame Impingement Issues

When fire, especially a torch-like flame, impinges on a tank, a high-volume hose stream directed at the point of flame contact may prevent a thinning of the tank and a pressure buildup within the tank. Torch fires occur when a tank has been punctured or the pressure relief valve functions as well as other sources where flammable gas is burning out of the opening in a strongly projecting flame. With this kind of fire, a large standoff distance is required, and unmanned monitor nozzles provide greater protection for responders than hand lines.

Situations where flooding with water may be inappropriate occur when the water temperature is higher than the temperature of the material in the tank. This is often the case during winter months. Additional factors to consider before attempting to cool a tank with water include the tank's construction (may be insulated and covered with a jacket), the supply of water, possible environmental damage from contaminated runoff, and ground saturation, which may prevent heavy equipment from entering the site to perform wreck clearing operations.

A water attack is almost never the first thing that emergency responders should attempt. The guidelines in this section, especially those relating to the initial notification, making an initial survey, collecting and interpreting hazard and response information, and reviewing the tank damage noted, should be followed prior to laying, charging, and using hose lines.

Rail Carrier Resources

Rail carriers maintain a staff of specialists (Hazmat Managers or Dangerous Goods Officers) trained to respond to rail related incidents and emergencies. These teams are strategically located throughout a carrier's network to assist company personnel and local emergency responders in mitigating emergency situations. These personnel have a variety of response tools and resources available to them, to ensure a safe and efficient handling of an incident.

These specialized teams also provide assistance and guidance in emergency planning efforts, as well as training in railway hazardous materials emergency response and tank cars.

Rail carriers provide a variety of training programs and delivery options through a commitment to TRANSCAERSM (Transportation Community Awareness Emergency Response). TRANSCAER is a national outreach program. Since 1986, the organization has focused on assisting communities to prepare for and respond to a possible hazardous material transportation incident. The TRANSCAER program is led by industry professionals who volunteer their time to support the mission to fit the needs of local responders. The purpose of TRANSCAER is to promote safe transportation and handling of hazardous materials, educate and assist communities near major transportation routes about hazardous materials, and aid community emergency response planning for hazardous material transportation incidents.

Rail carriers will provide bona fide emergency response agencies or planning groups with specific commodity flow information covering all hazardous commodities transported through the community for a 12-month period in rank order.

For more information on rail carrier training opportunities, please visit the website of the carrier that operates in your community or through TRANSCAER's website www.transcaer.com.

Section 8: Glossary of Railroad & Tank Car Terms

AAR — the Association of American Railroads, a trade association comprised of North American railroads. The AAR, among other activities, issues specifications and rules regarding the interchange of railcars between the various railroads. The AAR's requirements for tank cars are contained in the *AAR Manual of Standards and Recommended Practices* (MSRP) C-III, Specification M-1002.

AAR Specification Tank Car — a tank car built, altered, or converted in accordance with the tank car specifications of the Association of American Railroads.

AAR TC-128 Grade B Carbon Steel — an AAR specification for a high-strength carbon manganese steel plate for use in fusion-welded tank car tanks.

A-end — the end of a railcar, opposite the end equipped with the hand brake (see B-end.)

Ambient — the temperature and barometric pressure of the local environment.

B-end — the end of a railcar on which the hand brake is attached. If both ends of the railcar have a hand brake, the car will be stenciled "A-END" and "B-END". When facing the B-end, the sides of the railcar are identified as the Right Side and Left Side, respectively.

Body Bolster — the structural members at each end of a car body that support the car on its truck assemblies.

Bottom Outlet Valve — a valve located in the bottom of the tank for loading or unloading.

Bottom Washout — a plugged and flanged opening in the bottom of a tank to facilitate cleaning of a tank car that does not have a bottom outlet.

Brake Rigging — the assembly of cylinders, levers, and/or rods under a railcar that provides and transmits braking action to the wheels.

Breather Vent — a device having an operating part that is a permeable disc or a disc having a breather hole or slit. Breather vents are typically applied to tank cars transporting hydrogen peroxide to allow vapors created by the decomposition of the commodity to be vented from the tank.

Burst Pressure — the value of the inlet static pressure at which a rupture disc device or breaking-pin device functions.

Burst Pressure (Tank) — the internal pressure at which a tank will theoretically burst. For a tank car tank, the minimum burst pressure is based on the tank's inside diameter, welding joint efficiency, minimum tensile strength of the plate material, and the minimum thickness of the plate after forming.

CANUTEC — acronym for the Canadian Transport Emergency Centre. CANUTEC is operated by the Transport of Dangerous Goods Directorate of Transport Canada and provides a national bilingual (English and French) advisory service, including emergency response advice for incidents involving dangerous goods. Call collect at 613-996-6666 (24 hours) or *666 cellular (Canada only). Call 613-992-4624 (24 hours) for nonemergency inquiries.

Capacity/CAPY — the volumetric capacity (stenciled in gallons and liters) of a tank car's tank. The capacity may also be shown in imperial gallons.

Center Sill — the center longitudinal structural member of a car underframe that forms the backbone of the underframe and transmits most of the buffering shocks from one end of the car to the other (also see Stub Sill Tank Car).

Check Valve — a valve that automatically closes to stop the flow of liquid or vapor in one direction. A spring-loaded check valve has its valve maintained in the closed position by a spring and is opened by the valve above it.

CHEMTREC® — acronym for the Chemical Transportation Emergency Center, a 24-hour emergency response service that provides assistance in the handling of incidents involving hazardous materials/dangerous goods. Call toll free at 800-424-9300 in the U.S. and Canada (outside calls: collect at 703-527-3887).

C-Kit/Capping Kit — a set of components used to cap (cover) and contain leakage from a fitting on a tank car. C-Kits are specifically designed for use on chlorine and sulfur dioxide tank cars. Tank cars built or altered after December 1, 2003 and used for the transportation of Class 2 (gases) or Poison-Inhalation Hazard/Toxic Inhalation Hazard materials, must have a manway cover (or pressure plate) designed to accommodate capping kits. This requirement does not apply to tanks cars transporting carbon dioxide or Class DOT/TC-113 and Specification AAR-204W cryogenic liquid tank cars.

Clad/Cladding — the bonding of dissimilar metal sheets to form a composite material. The more corrosion-resistant metal acts as an interior protective coating after a tank car tank is fabricated.

Class (Tank Car) — a general designation of tank cars, usually including several specifications; e.g., Class DOT/TC-117 or Class AAR-204. The word "Class" is used if the designation embraces several specifications.

Closure — A category of service equipment with no operating components that closes an opening into a tank, valve or fitting. Examples: pipe plugs, quick-disconnect caps, blind flanges, manway covers, outlet caps, education pipe caps and fill hole covers.

Combination Pressure Relief Device — a type of pressure relief device that:

- A. has a breaking pin in combination with a reclosing pressure relief valve in which the breaking pin is located between the tank and pressure relief valve.
- B. has a rupture disc in combination with a reclosing pressure relief valve in which the rupture disc is located between the tank and pressure relief valve and may be located within the pressure plate.

Commodity/Lading — the product inside a tank car.

Consist — see Train List.

Coupler Vertical Restraint System — see "Double-Shelf Coupler" definition.

Cryogenic Liquid Tank Car — a vacuum-insulated tank car, consisting of an inner alloy (stainless) steel container (tank) enclosed within an outer carbon tank, not jacket, designed for the transportation of refrigerated liquefied gases, such as liquid hydrogen, oxygen, ethylene, nitrogen, methane/liquefied natural gas (LNG), and argon. These cars are built to the specifications contained in Subpart F, Part 179, 49CFR, for

Class DOT-113 tank cars; Section 8.6 of TC14877E for Class TC-113 tank cars; and Chapter 3 of the AAR Specifications for Tank Cars for Class AAR-204 tank cars. Cryogenic liquids are defined by:

- U. S.: 49CFR: “A refrigerated liquefied gas having a boiling point colder than -130°F (-90°C) at atmospheric pressure”; and
- Canada: TC TP 14877E: “A refrigerated liquefied gas that is handled or transported at a temperature equal to or less than -100°C (-148°F)”.

DOT — acronym for the Department of Transportation, which is the governmental department that regulates the transportation of hazardous materials within the United States.

DOT/TC Specification Tank Car — the U. S. Department of Transportation or Transport Canada specification to which a tank car was built, altered, or converted.

Double-Shelf Coupler/Coupler Vertical Restraint System — a railcar coupler having top and bottom shelves designed to prevent vertical disengagement of mating couplers in the event of an excessive speed end-to-end impact or derailment. Double-shelf couplers are fully compatible with all other railcar couplers and required by DOT regulation on all DOT specification tank cars and any tank car transporting hazardous materials/dangerous goods.

Eduction Line — the combination of the eduction valve and eduction pipe.

Eduction Pipe — the pipe that runs from the eduction valve into the tank.

Eduction Valve — a valve used to load or unload liquid product or to introduce or remove vapor from a tank car tank.

Expansion Dome (Dome) — a cylindrical metal enclosure, located on top of an obsolete nonpressure tank car tank, intended to function as the expansion area for the loading during transportation. Do not confuse an expansion dome with protective housing, which is found on pressure tank cars and some nonpressure tank cars.

Excess Flow Valve — a device designed to automatically close if the flow rate exceeds a specified value. The device, when installed in a liquid, vapor or sample line, closes automatically against the outward flow of the contents of the tank in case the external closure valve is broken off or removed during transit. When not in operation, the device allows the flow of liquid or vapor in two directions. Do not confuse this device with a check valve, which is a device that allows the flow of liquid or vapor in only one direction.

Fill Hole — an opening in the manway cover, closed with a fill-hole cover, through which product may be loaded or unloaded. Typically found on tank cars in sulfuric or hydrochloric acid service.

Fitting — a pressure retaining part that is in contact with the lading and has no operating components, made of one or more pieces, which joins service equipment to the tank car tank or joins two pieces of service equipment. This does not include gaskets or fasteners.

Fittings Plate — a bolted, circular-shaped metallic plate closing a nozzle to which the valves, safety/pressure relief device(s), and other fittings are mounted.

Flange — a disc-shaped device that is part of a nozzle or fitting (valve, PRD), used to create a bolted

attachment to the tank car. Also, it may be a solid disc (blind flange) or have a threaded hole for a plug or secondary valve bolted to the education valve to provide closure.

Gasket — material inserted in the joint between two mating surfaces to prevent leakage through the joint.

Gauging Device — a system that furnishes an indication of the liquid level inside a tank, not the visual gauge in the manway. Typically, these are a calibrated rod magnetically attached to a metal ball that floats on the lading; fixed-length tubes (telltale devices) or an electronic device. Nonpressure tank cars may be equipped with an interior fixed gauge bar/outage scale or a T-bar attached to the top of the tank below the manway nozzle.

Hand Brake — a device mounted on railcars and locomotives to provide a means for applying brakes manually without air pressure. Common types include vertical wheel, horizontal wheel, and lever type, so-named because of the configuration or orientation of their operating handles.

Head — one of the ellipsoidal ends of a tank car tank.

Head Shield — A method of providing tank head puncture-resistance by mounting a metal shield on the end of a tank car to protect against punctures from the coupler of another railcar. Head shields may be separate attachments or may be incorporated into a tank's jacket.

Heat Affected Zone (HAZ) — the area of a welded joint, adjacent to the weld material, where the base metal was not melted but had its microstructure and properties altered by heat of welding and subsequent re-cooling. This zone is less ductile than either the weld or the plate base material/parent metal due to the effect of the heat of welding.

Heel — common term used for the product or residue remaining in a tank car tank after it has been unloaded.

Insulation — a material, typically fiberglass or foam, enclosed within a metal jacket, used to maintain or moderate the temperature of the lading during transportation. For cryogenic liquid tank cars, in addition to a vacuum and insulation system, either perlite or an alternating wrap of multiple layers of aluminum foil and paper is used. Not all tank cars are insulated. Do not confuse insulation with thermal protection.

Interior Coating — any paint-type protective covering applied in one or more layers to the interior of a tank car tank to act as a barrier between the base metal and the commodity.

Interior Heater System — a piping system located within the tank that uses a thermal medium or electrical resistance to heat the lading within the tank for the purposes of unloading.

Interior Lining — any sheet or laminated type material (elastomer), glass, or fused metal applied to the interior of a tank car tank to act as a barrier between the base metal and the commodity.

Internal Valve — a type of bottom outlet valve located inside a tank car tank to prevent damage in the event of an accident.

Jacket — a metal covering (minimal thickness of 11 gauge) surrounding a tank car tank designed to protect and secure the insulation and/or thermal protection systems on a tank car. A jacket is not an outer tank.

Lading — the commodity being transported.

Light Weight/LT WT — empty weight or tare weight of a rail car. The light weight is stenciled in pounds and kilograms on every rail freight car and is abbreviated LT WT.

Liquid Eduction Line — a pipe, equipped with a valve, cap, or blind flange closure that extends to the bottom of a tank car tank for the loading and unloading of the lading.

Liquid Valve — any valve that is opened and closed manually or automatically to permit the passage of liquid into or out of the tank.

Load Limit/LD LMT — the maximum weight of lading that can be loaded in a railcar. Load limit is stenciled in pounds and kilograms on every rail freight car and is abbreviated LD LMT.

Manway — a general term designating the circular-shaped opening located at the top of a tank car tank to allow access into the tank's interior for maintenance, inspection, and loading or unloading. Depending upon a tank car's class or product service, the manway will be closed with either a hinged and bolted manway cover (typical for nonpressure tank cars) or a semi-permanently bolted manway cover or pressure plate, typical for pressure and cryogenic liquid tank cars.

Manway cover — the closure for the manway that is either a hinged and bolted manway cover or a semi-permanently bolted manway cover or pressure plate.

Nonpressure Tank Car — a tank car with a tank test pressure of 60 or 100 psig, built to the specifications contained in Subpart D, Part 179, Title 49CFR or Chapter 3, *AAR Manual of Standards and Recommended Practices*, Section C-III, Specification M-1002. Nonpressure tank cars are also referred to as "low pressure" or "general service" tank cars in the *2020 Emergency Response Guidebook*.

Normalized Steel — steel plate that has been heated and held at elevated temperatures (usually 1600 to 1700°F) followed by still-air or forced-air cooling. Normalization is a kind of heat treatment that relieves stress on steel and improves ductility and toughness.

Nozzle — a walled cylinder of circular or oval cross-section that is attached to the tank shell or tank head. A nozzle projects away from the tank attachment and terminates at a connection. A nozzle is used for the application of a manway cover, pressure or fittings plate, valves, pressure relief devices, and other fittings.

Outage — the vacant space left in a tank car tank after filling to allow for product expansion during transportation so it will not reach shell-full capacity (maximum volume of a tank). Governmental regulations prescribe minimum outages for hazardous materials/dangerous goods at specified reference temperatures. In addition to minimum outage by volume, tank cars may not be loaded by weight in excess of their gross weight on rail limit as determined by their truck capacity. Another term for outage is ullage.

Packing — a general term denoting the various substances and devices used to prevent leakage of fluids or gases through openings (valve body and valve stem) that cannot be closed by ordinary contact of the parts concerned.

Packing Gland — the portion(s) of a device used to contain packing on a valve body or other fitting to prevent leakage.

Pad — introduction of an inert gas under pressure, (typically nitrogen) into a tank car tank to provide an inert atmosphere for a lading that may react with air in order to protect the lading’s purity, or to create a non-flammable or moisture-free atmosphere.

PIH/TIH (Poison/Toxic Inhalation Hazard) — a gas or liquid that meets the definition of a “material poisonous by inhalation” as defined in §171.8, Title 49 CFR (see TIH).

Pressure Plate — a bolted, circular-shaped metallic plate closing a manway nozzle to which the valves, safety/pressure relief device(s), and other fittings are mounted.

Pressure Relief Device (PRD) — a fitting that opens at a predetermined setting to reduce the pressure within a tank car tank resulting from exposure to abnormal conditions. PRDs may be reclosing (spring-loaded) pressure relief valves, regulating valves, nonreclosing rupture disc devices/safety vents, or a combination device (incorporating both a rupture disc/breaking pin and a reclosing pressure relief valve). The term “Pressure Relief Device” is synonymous with “Safety Relief Device”; however, AAR uses the term “Safety Relief Device” in its documents.

Pressure Relief Valve (PRV) — a reclosing spring-loaded device, actuated by inlet static pressure, that relieves excess pressure and recloses after normal conditions are restored. “Pressure relief valve” has replaced the term “safety relief valve”.

Pressure Tank Car — a tank car with a tank test pressure of 100 to 500 psig built to the specifications contained in Subpart C, Part 179, Title 49CFR.

Protective Housing — on pressure and some nonpressure tank cars, a heavy, circular steel housing that surrounds the fittings to protect them in the event of an accident and from unauthorized access. Nonpressure tank cars may be equipped with light-gauge steel protective housings (referred to as combination housings, breadboxes, or mailboxes) that provide weather and tamper protection. Do not confuse with an expansion dome as found on some obsolete nonpressure tank cars. The protective housings for cryogenic liquid tank cars are boxes or cabinets on the sides or end of the tank car.

Protective Skids – structure on top of a nonpressure tank car which provides top fittings discontinuity protection.

Purging — the replacement of air or other vapors in a tank car by introducing inert gas under low pressure and venting the resulting gas mixture. Purging is generally used as part of the cleaning operation for tank cars or for cars being prepared for a change in commodity service.

Regulating (Regulator) Valve — a reclosing (spring-loaded) pressure relief device applied to tank cars transporting certain refrigerated liquids (e.g., carbon dioxide and argon) to maintain internal pressure below a certain point. If the pressure exceeds a specific point, the valve will open, releasing vapor, which results in auto-refrigeration, lowering the product’s temperature and pressure.

Reporting Mark and Number — the alphabetic initial stenciled (typically 3 or 4 letters ending with an X for non-railroad owned cars, followed by 1 to 6 numerals, e.g., BOEX 2021) on the sides and ends of every freight car to identify the railroad or private car line that owns the car. Reporting marks are assigned by the Association of American Railroads.

Residue — the amount of commodity remaining in a tank car after it has been unloaded to the maximum extent practicable. Also referred to as “the heel”.

Rupture Disc — the operating part of a rupture disc device/safety vent, which is designed to fail at a specific pressure. When used in combination with a spring-loaded reclosing pressure relief valve, the device is called a combination pressure relief device/valve. (Replaces the term “frangible disc”.)

Rupture Disc Device — a nonreclosing pressure relief device actuated by inlet static pressure and designed to function by the bursting of a rupture disc. These devices are also referred to as “safety vents” by DOT and TC. (See Safety Vent.)

Safety Relief Device — a category of service equipment that is designed to protect the tank car tank from internal pressure or vacuum in excess of specified settings. The term “Safety Relief Device” is synonymous with “Pressure Relief Device”; however, AAR uses the term “Safety Relief Device” in its documents.

Safety Relief Valve — See Pressure Relief Valve. Pressure relief valve has replaced the term safety relief valve.

Safety Systems — thermal protection, insulation, tank head puncture-resistance, coupler vertical-restraint and systems used to protect discontinuities and service equipment; e.g., skid protection and protective housings.

Safety Vent — a nonreclosing pressure relief device utilizing a rupture disc. The term is synonymous with “rupture disc device” (AAR) and is a term used by DOT and TC. (See Rupture Disc Device.)

Sample Line — a pipe (typically 1/4 inch in diameter), equipped with a control valve that extends to near the bottom of a tank car tank for drawing a sample of the lading.

Shell — the cylindrical section of a tank car tank, without heads. Do not confuse with jacket. (See Tank Car and Head.)

Service Equipment — equipment used for filling, sampling, emptying, venting, vacuum relief, pressure relief, heating (if internal to the tank), lading temperature measurement, or measuring the amount of lading within the tank. Commonly referred to as valves and fittings.

SETIQ — acronym for the Mexican Emergency Transportation System for the Chemical Industry, a service of the National Association of Chemical Industries (ANIQ). Responders in the Mexican Republic can call SETIQ (24 hours) 01-800-00-214-00. In Mexico City and the metropolitan area, call 5559-1588. Elsewhere call, call +52-55-5559-1588.

Shipping Paper/Shipping Document — document (paper or electronic) containing the information required by governmental regulations on a hazardous materials or dangerous goods shipment.

Skid Protection — a device attached to the bottom of a tank car to protect the bottom outlet, washout and/or sump (referred to as bottom discontinuities) from damage in the event of a derailment.

Specification — the specific designation within a tank car class; e.g., DOT-111A100W2.

STC Code or STCC — abbreviation for Standard Transportation Commodity Code, which is a 7-digit freight description coding system used by the North American railroad industry. For hazardous materials/dangerous goods, the STCC is referred to as the Hazmat Code, and begins with 49 or 48 for hazardous wastes. The Hazmat Code may be found on shipping papers/shipping documents and may be used to access computer-based emergency response information.

Stenciling — a term used to describe all forms of lettering on cars regardless of the actual method of application. Specific information that is required to be marked on the exterior surface of a tank car.

Stub Sill Tank Car — a tank car design with draft sills at each end of the tank instead of a continuous center sill that utilizes the tank as part of the car structure. (Also see Center Sill.)

Stuffing Box — the portion of a top-operated bottom outlet valve assembly through which the valve operating rod passes to the exterior of the tank. The stuffing box contains packing that, when compressed by the packing gland nut, forms a seal around the rod to prevent leakage and keeps the rod from vibrating. The stuffing box cover, when removed and inverted, is used as a wrench to open and close the internal valve.

Sump — a small depression located near the longitudinal center of a tank bottom where the liquid eduction line extends, thereby allowing the maximum amount of product to be removed from the tank.

Surge Pressure Reduction Device — a device that reduces the internal surge pressures at the pressure relief device interface when used in conjunction with a rupture disc.

TC-128 Grade B Carbon Steel — see AAR TC-128 Grade B Carbon Steel.

Tank Car/Tank Car Tank — a railcar that has a tank for its body for transporting liquids, solids, and liquefied gases, consisting of a shell and heads together with connections welded directly to it. In accordance with AAR specifications, “tank” means “tank car tank”. The head of a tank is one of the end closures. Tank cars may be pressure or nonpressure and are often equipped with special equipment to enhance their usefulness for handling specific commodities. For pressure class tank cars, the tank includes the manway nozzle as well.

Note: *Tanker or tanker car are inappropriate terms to describe a tank car.*

Tank Design Specification — the specific designation to which the tank car is built (e.g., DOT-117A100W) and does not include the features that make up the stenciled specification. The tank design specification will be found on the tank identification plate on the right side (AR) and left side (BL) body bolster web.

Tank Stenciled Specification — is the specific designation to which the tank car operates (e.g., DOT-117J100W) which includes features, such as insulation, thermal protection, head shields, and top fillings protection. The tank stenciled specification is located on the dies of the tank car near the qualification stencil.

Tank Test Pressure — the pressure (psig) at which a tank car tank is to be hydrostatically tested at the time of construction. Depending upon the specification, the tank test pressure varies from 20 percent to 40 percent of the minimum burst pressure. Tank test pressure is also known as service pressure.

TC or Transport Canada — the governmental agency that regulates the transportation of dangerous goods in Canada.

Thermal Protection — a material or system applied to tank car tanks to limit the transfer of heat to the tank in the event of exposure to pool or torch fires. It is intended to reduce the likelihood of tank failure under such conditions. Thermal protection is not the same as insulation, which is intended to maintain or moderate lading temperature under ambient conditions. Per 49CFR, a thermal protection system must have sufficient thermal resistance so there will be no release of any lading within a tank car, except through the pressure relief device, when subjected to:

- A pool fire for 100 minutes; and/or,
- A torch fire for 30 minutes.

Thermometer Well — a small diameter pipe, usually 3/4 inch, filled with an antifreeze solution or oil that extends into the tank and is closed at the top with a removable cap. The temperature of the lading transfers to the liquid in the pipe. A thermometer or probe is lowered into the pipe to obtain the lading's temperature.

TIH/PIH (Toxic/Poison Inhalation Hazard) — a gas or liquid that meets the definition of a “material poisonous by inhalation” as defined in §171.8, Title 49 CFR (see PIH).

Train Consist — for purposes here, a document (also referred to as a Train List or Wheel Report) that sequentially lists the location of each railcar in a train. A consist may also serve as the shipping paper/document for a railcar containing hazardous materials/dangerous goods, provided it contains all of the information required by governmental regulations.

Truck — the assembly of wheels, axles, roller bearings, springs, side bearings, side frames, and bolster that supports each end of a railcar and enables it to move on the rails.

Type (Tank Car) — for tank cars, designates the approving authority (DOT, TC, or AAR). Preferred usage is, for example, “DOT tank cars”.

Vacuum Relief Valve — a spring-loaded valve mounted at the top of some nonpressure tank cars, designed to open and allow air into the tank if an excessive vacuum is formed that may cause the tank to collapse. A vacuum relief valve should not be depressed to determine if there is pressure in the tank. Doing so may dislodge the sealing component causing the device to leak vapor or liquid.

Valves — A device attached to a tank car tank designed to control the flow of lading into and out of the tank. Purposes include but are not limited to measure fluid pressure and temperature, sample fluids in the tank, detect or determine liquid levels, or relieve over-pressures for the purpose of emergency relief or temperature control.

Vapor Line — a pipe equipped with a valve, cap, or blind flange closure that extends to the top of the tank through which vapor is introduced or removed during loading or unloading. On a nonpressure tank car, this device is usually called an air line and is used to introduce compressed air or vapor, or an inert gas to unload the car.

Vapor Valve — any valve that is opened or closed manually or automatically to permit the passage of vapor into or out of the tank.

Vapor Space — the space in a tank above the liquid; may also be referred to as outage.

Wheel Report — see Train List.

Annex A: AAR, U.S. DOT, & Transport Canada Safety Enhancements for Nonpressure Tank Cars

Note: The intent of this Annex is to provide a historical timeline of the various rule changes regarding the transportation of flammable liquids by tank car.

AAR-INITIATED SAFETY ENHANCEMENTS FOR NONPRESSURE TANK CARS

Top Fittings Protection for Tank Cars in Sulfuric Acid Service.

With certain exceptions, nonpressure tank cars ordered new after June 10, 2010, are required to have top-fitted service equipment protection. Top fittings protection is typically met by the installation of a protective device or structure.

Top Fittings Protection for Tank Cars Used to Transport Packing Group I & II Materials

For protection of top fittings against rollovers and accidental horizontal loads, all new nonpressure Class DOT/TC tank cars ordered after July 1, 2010, used to transport all Packing Group I and II materials, are required to have top fitting protection. Currently, there are no requirements to retrofit existing tank cars (refer to the following “DOT Regulations for Tank Cars in High-Hazard Flammable Train Service” regarding tank cars transporting Class 3 (flammable liquids).

Tank Cars Built for the Transportation of Class 3 (Flammable Liquids)

In September 2011, the AAR published, via Casualty Prevention Circular (CPC) 1232, new requirements in Chapter 2 of the AAR Specifications for Tank Cars for tank cars built for the transportation of Class 3 (flammable liquids) Packing Group I and II, with the proper shipping names of “Petroleum Crude Oil”, “Alcohols, n.o.s.”, and “Ethanol and Gasoline Mixture”.

Class-111 tank cars ordered after October 1, 2011, are required to comply with the following requirements:

- 1) **Top Fittings Protection:** Must have top fittings protection per Appendix E; typically met by enclosing the fittings within a protective housing.
- 2) **Pressure Relief Devices (PRDs):** Must be equipped with reclosing pressure relief devices. Upon approval by DOT’s Pipeline and Hazardous Materials Administration (PHMSA), a nonreclosing device can be used where the applicant demonstrates that a nonreclosing device is required and affords an equivalent level of safety.
- 3) **Tank Material:** Heads and shells must be constructed of normalized AAR TC128 Grade B steel or normalized ASTM A516-70 steel. Tank heads must be normalized after forming. The AAR Executive Director of Tank Car Safety may approve non-normalization after forming if a facility has demonstrated that its equipment and controls provide an equivalent level of safety.
- 4) **Tank Thickness**
 - Tanks constructed of normalized AAR TC128 Grade B steel:
 - Non-jacketed tanks must be at least 1/2- inch thick; and
 - Jacketed tanks must be at least 7/16-inch thick.
 - Tanks constructed of normalized ASTM A516-70 steel:
 - Non-jacketed tanks must be at least 5/8-inch thick; and
 - Jacketed tanks must be at least 1/2-inch thick.

In all cases, the cars must be equipped with at least 1/2-inch-thick half-head shields.

- Tanks constructed of alloy (stainless) steel (DOT-111****W6 and DOT 111****W7):
 - Non-jacketed tanks must have heads and shells at least 1/2-inch thick and be equipped with 1/2-inch-thick half-head shields, and
 - Jacketed tanks must be at least 7/16-inch thick and equipped with, at a minimum, 1/2-inch-thick jacket heads.

Tank cars built to meet the above requirements are referred to as “CPC-1232 tank cars”. Tank cars built prior to the CPC-1232 standards being used to transport the above commodities are commonly referred to as “legacy tank cars.”

U.S. DOT REGULATIONS FOR TANK CARS IN CLASS 3 (FLAMMABLE LIQUID) SERVICE

Tank Cars in “High-Hazard Flammable Train Service”

On May 8, 2015, the Department of Transportation established a new tank car specification, “DOT 117A100W” to be utilized for the transportation of all Class 3 (flammable liquids) (not just Crude Oil and certain Alcohols (Ethanol), as covered by AAR’s CPC-1232). The rule also published a phase-out schedule for the use of existing Class DOT-111 (a/k/a “legacy tank cars”) and those CPC-1232 tank cars.

Excerpted from Title 49CFR:

§171.8: High-hazard flammable unit train (HHFUT): a single train transporting 70 or more loaded tank cars containing Class 3 (flammable liquid).

§174.310 Requirements for the operation of high-hazard flammable trains.

(a) Applicability. Each rail carrier operating a high-hazard flammable train (as defined in §171.8 of this subchapter) must comply with each of the following additional safety requirements with respect to each high-hazard flammable unit train that it operates:

(1) Routing. The additional planning requirements for transportation by rail in accordance with part 172, subpart I of this subchapter.

(2) Speed restrictions. All trains are limited to a maximum speed of 50 mph. The train is further limited to a maximum speed of 40 mph while that train travels within the limits of high-threat urban areas (HTUAs) as defined in §1580.3 of this title, unless all tank cars containing a Class 3 flammable liquid meet or exceed the DOT Specification 117 standards, the DOT Specification 117P performance standards, or the DOT Specification 117R retrofit standards provided in part 179, subpart D of this subchapter.

(3) Braking. Each rail carrier operating a high-hazard flammable train (as defined in §171.8 of this subchapter) operating at a speed in excess of 30 mph must ensure the train is equipped and operated with either a two-way end-of-train (EOT) device, as defined in 49 CFR 232.5, or a distributed power (DP) system, as defined in 49 CFR 229.5.

§§173.241(a), 173.242(a), and 173.243(a): Bulk packaging requirements. DOT-111 tank cars and DOT-111 tank cars built to the AAR’s CPC-1232 industry standard are no longer authorized to transport Class 3 (flammable liquids) in high-hazard flammable train service, unless retrofitted to DOT-117R retrofit standards, or meet the DOT-117P performance standards prescribed by §179.202-12. DOT-111 tank cars and DOT-111 CPC-1232 tank cars are no longer authorized for use in high-hazard flammable train service unless retrofitted prior to the dates shown in the table below.

DOT Phase-Out Dates for DOT-111 and DOT-111 CP-1232 Tank Cars in High-Hazard Flammable Train Service

(May 8, 2015; superseded by FAST Act on August 15, 2016 – see page 80)

PACKING GROUP	DOT 111 NOT AUTHORIZED ON OR AFTER:	DOT 111 CPC-1232 NOT AUTHORIZED ON OR AFTER:
I	January 1, 2018 – Non-jacketed	April 1, 2020 – Non-jacketed
	March 1, 2018 - Jacketed	May 1, 2025 - Jacketed
II	May 1, 2023 – Jacketed and Non-jacketed	July 1, 2023 – Non-jacketed
		May 1, 2025 - Jacketed
III	May 1, 2025	May 1, 2025

§179.202: Specification requirements for DOT-117 tank car tanks:

- **Plate thickness:** Minimum 9/16-inch thick, AAR TC-128 Grade B normalized carbon steel.
- **Tank head puncture resistance:** Full-height head shields at least 1/2-inch thick.
- **Thermal protection system:** Conforming to §179.18 and include a reclosing pressure relief device.
- **Jacket:** Minimum 11 gauge of A1011 steel, or equivalent. Insulation is optional.
- **Bottom outlet:** If equipped, the handle must be removed prior to train movement, or be designed with protection safety system(s) to prevent unintended actuation during accident scenarios.
- **Top fittings protection:** Top fittings protection conforming to Appendix E of the AAR Specifications for Tank Cars.

§179.202-13: Retrofit standard requirements for DOT117R. Existing DOT-111, including CPC-1232, tanks may be retrofitted to DOT-117 requirements provided:

- **Plate thickness:** The wall thickness after forming of the tank shell and heads must be, at a minimum, 7/16-inch thick and constructed with steel authorized by the DOT regulations at the time of construction (differs from DOT-117A specification).
- **Tank head puncture resistance:** Full-height head shields at least 1/2-inch thick (same as DOT-117A).
- **Thermal protection system:** Conforming to §179.18 and include a reclosing pressure relief device (same as DOT-117A).
- **Jacket:** Minimum 11 gauge of A1011 steel, or equivalent (same as DOT-117A). Insulation is optional. (same as DOT-117A).

- **Bottom outlet:** If equipped, the handle must be removed prior to train movement, or be designed with protection safety system(s) to prevent unintended actuation during accident scenarios (same as DOT-117A).
- **Top fittings protection:** Existing tank car tanks may continue to rely on the equipment installed at the time of manufacture (same as DOT-117A).

Tank car specification markings:

- DOT-117 tank cars are built to the specification “DOT-117A100W”; however, as jacketed thermal protection is required, they will be stenciled “DOT-117J100W.”
- Existing Class-111 and CPC-1232 tank cars that are retrofitted will be stenciled “DOT117R100W”.
- Existing Class-111 and CPC-1232 tank cars that meet the performance standards specified in §179.202-12 will be stenciled “DOT117P100W.”

Note: The DOT-117A100W specification does not include a numeral following the letter “W” as prescribed for other Class DOT-111A nonpressure tank cars (i.e., “1” – “7”).

Transportation of Flammable Liquids by Rail (excerpted from “Fixing America’s Surface Transportation Act”) (a/k/a “FAST Act” – October 1, 2015 – signed into law on December 4, 2015)

The “FAST Act” revised the May 8, 2015, DOT rulemaking for Tank Cars in High-Hazard Flammable Train Service to include all Class 3 (flammable liquids) materials transported by rail (not just those transported in a high-hazard flammable train (HHFT) or a highhazard flammable unit train (HHFUT)).

§7304: Phase-out of all Tank Cars Used to Transport Class 3 (Flammable Liquids)

- Except as provided in subsection (b), beginning on 10/1/2015, all DOT-111 specification railroad tank cars used to transport Class 3 (flammable liquids) shall meet the DOT-117, DOT-117P, or DOT-117R specifications in Part 179 of Title 49, CFR, regardless of train composition.
- Phase-out schedule: As of 10/1/2015, certain tank cars not meeting DOT-117, DOT-117P, or DOT-117R specifications may be used regardless of train composition, until the enddates shown in the table to the right: (Superseded by FAST Act August 15, 2016.)

DOT Phase-Out Dates for Non-DOT-117 Tank Cars in Class 3 (Flammable Liquids) Service (10/1/2015)

COMMODITY	TANK CAR	END-DATE
Class 3 Unrefined Petroleum Products, including Crude Oil	Non-jacketed DOT-111	January 1, 2018
	Jacketed DOT-111	March 1, 2018
	Non-jacketed CPC-1232	April 1, 2020
	Jacketed CPC-1232	May 1, 2025
Ethanol	Non-jacketed and jacketed DOT-111	May 1, 2023
	Non-jacketed CPC-1232	July 1, 2023
	Jacketed CPC-1232	May 1, 2025
Other Class 3 (Flammable Liquids) – Packing Group I	DOT-111 and CPC-1232	May 1, 2025
Other Class 3 (Flammable Liquids) – Packing Groups II and III	DOT-111 and CPC-1232	May 1, 2029

§7305 Thermal Blankets: DOT-117 and non-jacketed tank cars modified to meet the DOT-117R specification must be equipped with an insulating thermal blanket at least 1/2 inch thick.

§7306: Minimum Requirements for Top Fittings Protection for DOT-117 Tank Cars:

- A. **Protective Housing** - Except as provided in (b) and (c), top fittings on DOT-117R tank cars shall be located inside a protective housing not less than 1/2- inch thick; and
1. Shall be as tall as the tallest valve or fitting involved and the height of a valve or fitting within the protective housing must be kept to the minimum compatible with their operation.
 2. The protective housing or cover may not reduce the flow capacity of the pressure relief device below the minimum required.
 3. The protective housing shall provide a means of drainage with a minimum flow area equivalent to 6- inch diameter holes.
 4. When connected to the nozzle or fittings cover plate, and subject to a horizontal force applied perpendicular to, and uniformly over, the projected plane of the housing, the tensile connection strength of the housing shall be designed to be:
 - a) no greater than 70% of the nozzle to tank tensile connection strength;
 - b) no greater than 70% of the cover plate to nozzle connection strength; and
 - c) no less than either 40% of the nozzle to tank connection strength or the shear strength of twenty 1/2-inch bolts.
- B. **Pressure Relief Devices (PRD):**
1. The PRD shall be located inside the protective housing, unless space does not permit. If multiple PRDs are utilized, no more than one may be located outside of the housing.
 2. The highest point of any PRD located outside of the housing may not be more than 12 inches above the tank jacket.
 3. The highest point on the closure of any unused PRD nozzle may not be more than 6 inches above the tank jacket.
- C. **Alternative Protection:** As an alternative to the protective housing requirements, a tank car may be equipped with a system that prevents the release of product from any top fitting in the case of an incident where the top fitting would be sheared off.

“Fast Act” Requirements for Flammable Liquids and Rail Tank Cars

On August 10, 2016, the Department of Transportation issued Final Rule HM-251C to codify certain mandates and minimum requirements of the “FAST Act” into Title 49CFR. The table on the following page summarizes the DOT phase-out of non-DOT 117 tank cars in Class 3 (flammable liquids) service: In addition, 49CFR, Part 179, Specifications for Tank Cars, was revised to include the “FAST Act” requirements applicable to DOT Specification 117A, 117P and 117R tank cars.

DOT Phase-Out Dates for Non-DOT-117 Tank Cars in Class 3 (Flammable Liquids)

(as of 08/15/2016)

Material	Jacketed or Non-jacketed Tank Cars	DOT-111 not authorized on or after:	DOT-111 CPC-1232 not authorized on or after:
Unrefined petroleum products – Class 3, PG I (e.g., Crude Oil)	Non-jacketed	January 1, 2018	April 1, 2020
	Jacketed	March 1, 2018	May 1, 2025
Class 3, PG I (flammable liquid), other than unrefined petroleum products	Non-jacketed	May 1, 2025	May 1, 2025
	Jacketed	May 1, 2025	May 1, 2025
Unrefined petroleum product – Class 3, PG II or PG III (flammable liquid)	Non-jacketed	January 1, 2018	April 1, 2020
	Jacketed	March 1, 2018	May 1, 2025
Ethanol	Non-jacketed	May 1, 2023	July 1, 2023
	Jacketed	May 1, 2023	May 1, 2025
Class 3, PG II or PG III (flammable liquid) other than unrefined petroleum products or ethanol (see above)	Non-jacketed	May 1, 2029	May 1, 2029
	Jacketed	May 1, 2029	May 1, 2029

TRANSPORT CANADA REGULATIONS FOR TANK CARS

Transport Canada Protective Direction No. 34

Issued April 23, 2014, Protective Direction (PD) No. 34 required owners to identify and report to Transport Canada each CTC (Canadian Transport Commission) 111, DOT 111 and AAR 211 stub sill tank cars with certain construction characteristics (non-normalized ASTM A515 Grade 70 steel shell material; not having exterior heater coils; and, not having bottom-shell continuous reinforcement).

Subject tank cars cannot be offered for transport or transported in Canada. In addition, these tank cars are required to be marked “Do not load with dangerous goods in Canada/Ne pas charger de marchandises dangereuses au Canada”, or similar words to that effect. On May 2, 2014, AAR issued CPC-1281 requiring such marking to be placed on both sides of the tank car adjacent to the car number on a stencil or decal measuring approximately 10 1/2 by 20 1/2 inches (see sample to the right).

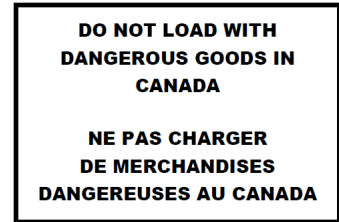

TC-117 Tank Cars for Flammable Liquids

On May 1, 2015, the Transportation of Dangerous Goods (TDG) Regulations were amended to incorporate a TC-117 tank car specification for the transport of flammable liquids. The TC-117 specification, including TC-117P and TC-117R, is equivalent to DOT-117, DOT-117P, and DOT-117R tank cars; however, all TC117 tank cars are not required to be equipped with ECP (Electronically Controlled Pneumatic) brakes.

As of October 1, 2015, TC-117 tank cars are the only nonpressure tank cars permitted to be built for flammable liquid service. TC/DOT-111 tank cars manufactured before October 1, 2015, (including CPC1232 tank cars) may be retrofitted for continued use for the transport of flammable liquids. Such tank cars will be designated as TC-117R. Per Transport Canada Protective Order 37, issued June 6, 2016, the retrofit requirements, including application of a protective housing around the service equipment mounted on the manway cover plate, are the same as the retrofit requirements for DOT-117R tank cars under the United States’ “FAST Act.”

Transport Canada has published phase-out schedules for tank cars transporting flammable liquids (See Protective Directions No. 38 and 39).

Transport Canada Protective Direction No. 38

On July 13, 2016, Protective Direction 38 was issued to accelerate the phase-out of jacketed and non-jacketed “legacy” (non-CPC-1232) DOT-111 tank cars from being used to transport Crude Oil in Canada as of November 1, 2016. Prior to PD 38, the cut-off dates for Crude Oil were May 1, 2017, for DOT-111 non-jacketed tank cars and March 1, 2018 for jacketed tank cars.

Transport Canada Phase-Out Schedule for Tank Cars Transporting Class 3 (Flammable Liquids)

Cut-off Date	Flammable Liquid/Packing Group	TC/DOT-111 removed from service
November 1, 2016	Crude Oil, PG I, II, and III	Non-CPC-1232, non-jacketed “Legacy tank cars”
November 1, 2016	Crude Oil, PG I, II, and III	Non-CPC-1232, jacketed “Legacy tank cars”
April 1, 2020	Crude Oil, PG I, II, and III	CPC-1232, non-jacketed
May 1, 2023	Ethanol, PG II	Non-CPC-1232, non-jacketed; non-CPC-1232, jacketed
July 1, 2023	Ethanol, PG II	CPC-1232, non-jacketed
May 1, 2025	Crude Oil and Ethanol, PG I, II, and III	CPC-1232, jacketed*
May 1, 2025	All other flammable Liquids, PG I, II and III	Non-CPC, non-jacketed; non-CPC, jacketed; CPC-1232, non-jacketed; CPC-1232, jacketed*

*Most jacketed CPC-1232 tank cars will meet the requirements of TC-117R, with minor changes, if any.

Transport Canada Protective Direction No. 39

On August 28, 2018, Protective Direction 39 was issued to accelerate the provisions of Protective Direction No. 38 addressing the removal of the CPC 1232 (TP14877) unjacketed tank cars from crude oil service in Canada from the current April 1, 2020 regulatory requirement to November 1, 2018. It also accelerates the removal of all TC/DOT 111 and CPC 1232 (TP14877) unjacketed tank cars from condensate service in Canada from the current April 30, 2025 regulatory requirement to January 1, 2019.

Transport Canada Accelerated Phase-Out Schedule for Tank Cars Transporting Class 3 (Flammable Liquids)

Cut-off Date	Original Phase Out Date	Accelerated Phase Out Date
Tank cars from ethanol service (UN1170, UN1987, UN1993 and UN3475)		
Legacy Class 111 tank cars	May 1, 2023	Prohibited
Unjacketed enhanced 111 tank cars	July 1, 2023	Prohibited
Jacketed enhanced 111 tank cars	May 1, 2025	Prohibited
Tank cars from crude oil service (UN1267, UN1268 and UN3494)		
Legacy Class 111 tank cars	March 1, 2018	November 1, 2016
Unjacketed enhanced 111 tank cars	April 1, 2020	November 1, 2018
Jacketed enhanced 111 tank cars	May 1, 2025	Prohibited
Tank cars from condensate service (UN1265, UN1268, UN1993 and UN 3295)		
Legacy Class 111 tank cars	April 30, 2025	December 31, 2018
Unjacketed enhanced 111 tank cars	April 30, 2025	December 31, 2018
Jacketed enhanced 111 tank cars	May 1, 2025	Prohibited
Tank cars from other flammable liquids		
Legacy Class 111 tank cars	May 1, 2025	Prohibited
Unjacketed enhanced 111 tank cars	May 1, 2025	Prohibited
Jacketed enhanced 111 tank cars	May 1, 2025	Prohibited